

# VM-Series

CAN Bus Rocker Switch  
Module

[PRODUCT WEBPAGE](#)

*request sample, watch video*



The sealed VM-Series incorporates the Contura® switches actuator style flexibility with CAN Bus technology to create a multiplexed rocker switch module. Additionally, the VM-Series increases product reliability, while reducing the complexity of wire harnesses and improving assembly efficiencies.

**12/24**  
VDC

**250,000**  
Operations

**IP68 Sealing**  
Above and below panel

## Typical Applications

- Commercial Vehicles
- Construction Equipment
- Agricultural Equipment
- Work Trucks

# Design Features

## IP68 SEALING PROTECTION

Fully sealed above panel and below panel (when connected)



Front View

### ROCKERS

Variety of removable V-Series Contura® actuator styles

### CUSTOMIZABLE ICONS

Choose from our extensive library of legends, or customize your own.

Back View

VM6

### SNAP-IN MOUNTING

For fast, easy assembly.



### 6 PIN CONNECTOR

Mates to the Deutsch DT-Series Connector.

### 4 PIN CONNECTOR

Mates to the Deutsch DT-Series Connector. Can be used to Daisy-chain multiple VM-Series.

# Related Products



**CLTM12-S-Series >**  
Load Controller



**CKJ-Series >**  
Jog Switch



**CKP-Series >**  
Customizable Keypad

# Tech Specs

## Electrical

|  |             |  |
|--|-------------|--|
| Operating Voltage                            |             | 12 or 24VDC systems  |
| Maximum Current                              |             | <b>VM3:</b> Operation: 90mA; Sleep mode: 8mA<br><b>VM6:</b> Operation: 130mA; Sleep mode: 8mA                    |
| Electrical Endurance                         |             | Minimum 250,000 operations (50,000 cycles at -40°C, 150,000 cycles at room temperature, & 50,000 cycles at 85°C) |
| Over Voltage                                 | ISO 16750-2 | Apply voltage 36VDC for 60 min at 65°C   |
| Short Circuit Protection                     | ISO 16750-2 | All signal inputs and outputs short to ground for 60s  |
| Reverse Polarity Protection                  | ISO 16750-2 | 12 VDC systems: -24VDC for 5 minutes<br>24 VDC systems: -36VDC for 5 minutes                                     |
| Starting Profile                             | ISO 16750-2 | Class A  |
| Withstand Voltage                            | ISO 16750-2 | 500Vrms (50 Hz to 60 Hz) with a duration of 60s  |
| Insulation Resistance                        | ISO 16750-2 | Minimum 10 Mohms at 500 VDC with a duration of 60s   |
| Superimposed Alternating Voltage             | ISO 16750-2 | Severity 2, Upp of 4V for Un=12V and Un=24V  |
| Slow Decrease and Increase of Supply Voltage | ISO 16750-2 | Power supply from 8V to 0V, 0V to 8V, (rate of 0.5 ± 0.1V/min linear)  |
| Momentary Drop in Supply Voltage             | ISO 16750-2 | Voltage drop from 8V to 4.5V for 12V system, 16V to 9V for 24V system. Dwell time 10ms.                          |

## Electromagnetic Compatibility (EMC)

|                        |             |  |
|------------------------|-------------|--|
| ESD                    | ISO 10605   | ±15kV air discharges, ±8kV contact discharges  |
| Absorbed-Lined Chamber | ISO 11452-2 | 100V/m, 80MHz to 2GHz  |
| Bulk Current Injection | ISO 11452-4 | 100mA, 20MHz to 400MHz   |
| Conducted Transients   | ISO 7637-2  | All test pulses according to ISO 7637, Annex table A2 for 24V systems, level 3 minimum |
| Transient Emissions    | ISO 13766   | Annex D and E, 30MHz to 1GHz   |

## Environmental

|                       |                |   |
|-----------------------|----------------|---|
| Operating Temperature |                | -40 °C to + 85°C  |
| Storage Temperature   |                | -40°C to + 85°C   |
| Thermal, Hot Soak     | IEC 60068-2-2  | Test Bb, 85°C for 96 hours  |
| Thermal, Cold Soak    | IEC 60068-2-1  | Test Ad, -40°C for 96 hours   |
| Thermal Shock         | IEC 60068-2-14 | Test Na, -40°C to 85°C, 1 hour per cycle (30 minutes at 40°C, 30 minutes at 85°C) 10 cycles                       |
| Thermal Cycling       | IEC 60068-2-14 | Test Nb, -40°C to 85°C, 2 cycles of 8 hours each  |
| Sealing Protection    | IEC 60529      | IP68, for above and below panel components of actual switch only (when connected), 1.2m deep water for 60 ± 2 min |
| Solar Radiation       | IEC 60068-2-5  | Procedure B, 40°C for 10 days   |
| Humidity, Soak        | IEC 60068-2-78 | Test Cab, 30°C at 93% RH for 10 days  |
| Humidity, Cyclic      | IEC 60068-2-30 | Test Db, Method 1, 55°C to 25°C at >90% R.H., 6 cycles of 24 hours each   |
| Salt Spray            | IEC 60068-52   | Test Kb, severity level 4   |
| Chemical Resistance   | ISO 16750-5    | Method II for engine oil, hydraulic oil, diesel fuel, grease, and urea at max temperature                         |

# Tech Specs

## Mechanical

|                      |                |  |
|----------------------|----------------|--|
| Vibration, Random    | IEC 60068-2-64 | Test Fh, method 1, random excitation at 10, 150, 220 and 350 Hz breakpoint frequencies, 5 hours in each axis |
| Vibration, Resonance | IEC 60068-2-6  | Sinusoidal from 10-2000 Hz, 5 minutes at resonant points   |
| Vibration, General   | IEC 60068-2-6  | Swept sine wave from 5 to 500 Hz, ± 15mm amplitude, 5g, 20 cycles in each plane                              |
| Shock                | IEC 60068-2-27 | 3 shocks in each direction of the 3 axes (18 total shocks) at 500 m/s <sup>2</sup> for 11 ms                 |
| Bump                 | IEC 60068-2-27 | 100 shocks in each direction of the 3 axes (600 total shocks) at 400 m/s <sup>2</sup> for 6 ms               |
| Drop Test            | IEC 60068-2-31 | Test Ec, free fall procedure 1, drop in each direction of the 3 axes (6 total drops) from 500mm              |

## Physical

|                    |  |  |
|--------------------|--|--|
| Switch Functions   | 2-position maintained, 2-position momentary (top), 2-position momentary (bottom), 3-position maintained, 3-position maintained (top and bottom), 3-position maintained (top), 3-position maintained (bottom) |  |
| Illumination       | Single color LED (Red, Green, Amber, Blue, White) (See Table A)  |  |
| Soft Lock          | Yes  |  |
| Mounting           | Front panel, removable from a side   |  |
| Depth Behind Panel | Depth behind panel 41mm [1.6 in]   |  |
| Weight             | <b>VM3:</b> ~91 grams [0.2 lb]<br><b>VM6:</b> ~227 grams [0.5 lb]  |  |
| Materials          | Housing – Acetal, UV stabilized; Back cover – Acetal, UV stabilized; Rocker – Polycarbonate / Nylon; Mounting clips – Stainless Steel  |  |
| RoHS               | Yes  |  |
| REACH              | Yes  |  |
| Connector          | Deutsch DT-Series 4 and 6 pin (6 pin for VM6 only)   |  |

## Software

|               |  |  |
|---------------|--|--|
| Communication | Supported Protocols and baud rates:<br><ol style="list-style-type: none"> <li><b>1. SAE J1939</b> <ol style="list-style-type: none"> <li>a. Baud Rates           <ol style="list-style-type: none"> <li>i. 125 Kbps</li> <li>ii. 250 Kbps</li> <li>iii. 500 Kbps</li> </ol> </li> </ol> </li> <li><b>2. NMEA2000</b> <ol style="list-style-type: none"> <li>a. 250 Kbps</li> </ol> </li> <li><b>3. CANopen &lt;Add Profile&gt;</b> <ol style="list-style-type: none"> <li>a. Baud Rates           <ol style="list-style-type: none"> <li>i. 125 Kbps</li> <li>ii. 250 Kbps</li> <li>iii. 500 Kbps</li> </ol> </li> </ol> </li> </ol> |  |
| Bootloader    | Allows in-network update of application software when using qualified CAN diagnostic tools.  |  |
| Programming   | During manufacture or via CAN  |  |
| Sleep Mode    | Any switch can be configured to wake the unit, which also activates the switch function.   |  |
| Dimming       | LED dimming controlled by ECU through CAN bus  |  |

## Certification

|        |            |                            |
|--------|------------|----------------------------|
| E-Mark | ECE/R10.05 | No.: E11*10R05/01*11680*00 |
|--------|------------|----------------------------|

# Tech Specs

## Software Interface Integration

Click below on integrating the VM-Series into a

J1939 CAN network: [www.carlingtech.com/vm-series\\_j1939-interface.pdf](http://www.carlingtech.com/vm-series_j1939-interface.pdf)

CANopen network: [www.carlingtech.com/vm-series\\_CANopen-interface.pdf](http://www.carlingtech.com/vm-series_CANopen-interface.pdf)

## Tables

**Table A:** Illumination Table (for each switch position)

| Location   | Type      | Color                            | Option                         |
|------------|-----------|----------------------------------|--------------------------------|
| Top LED    | Backlight | Red, Green, Amber, Blue or White | Continuous Flashing            |
|            | Function  | Red, Green, Amber, Blue or White | ON with Switch, ON with Device |
| Bottom LED | Backlight | Red, Green, Amber, Blue or White | Continuous Flashing            |
|            | Function  | Red, Green, Amber, Blue or White | ON with Switch, ON with Device |

**Table B:** Connector 1 Pinout for VM3

|                 | Pin           | 1   | 2   | 3     | 4     |
|-----------------|---------------|-----|-----|-------|-------|
| <b>Option 1</b> | <b>Signal</b> | VCC | GND | CAN_H | CAN_L |

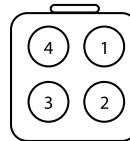

Figure 1:  
Connector 1 Pinout

**Table C:** Connector 1 Pinout for VM6

|                 | Pin           | 1     | 2     | 3     | 4     |
|-----------------|---------------|-------|-------|-------|-------|
| <b>Option 1</b> | <b>Signal</b> | VCC   | GND   | CAN_H | CAN_L |
| <b>Option 2</b> | <b>Signal</b> | Out 1 | Out 2 | Out 3 | Out 4 |

Note: Out 1 to Out 4 is to control loads with max output current 0.5A @ 24VDC

**Table D:** Connector 1 Pinout for VM6

|                 | Pin           | 1     | 2     | 3  | 4  | 5   | 6   |
|-----------------|---------------|-------|-------|----|----|-----|-----|
| <b>Option 1</b> | <b>Signal</b> | CAN_L | CAN_H | NC | NC | GND | VCC |

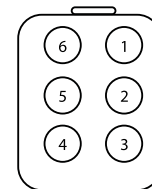

Figure 2:  
Connector 2  
Pinout

**Table E:** Operation Current Values

Size Voltage Sleep Current Value (mA) 100% Brightness Operating Current Value (mA) 10% Brightness Operating Current Value (mA)

| Size | Voltage | Sleep Current Value (mA) | 100% Brightness Operating Current Value (mA) | 10% Brightness Operating Current Value (mA) |
|------|---------|--------------------------|--|---|
| VM3  | 12      | ~7.15                    | ~78.72                                       | ~63.55                                      |
|      | 24      | ~6.75                    | ~42.38                                       | ~34.61                                      |
| VM6  | 12      | ~22.74                   | ~155.67                                      | ~111.61                                     |
|      | 24      | ~14.05                   | ~78.74                                       | ~57.94                                      |

# Ordering Scheme

## Part 1: Module and Rocker Style

Sample Part No. **VM 6 - 1 F 1 - 1 000**

Selection 1 2 3 4 5 6 7

### 1. SERIES

**VM** V-Series Module System

### 2. SIZE

**3** 3 Position  
**6** 6 Position

### 3. COMMUNICATION PROTOCOL

**1** J1939  
**3** J1939 with Control Relay (6 position size only)  
**4** CANopen <sup>1</sup>  
**5** CANopen with Control Relay (6 position size only) <sup>1</sup>

### 4. ROCKER STYLE <sup>2</sup>

**A** Contura II  
**B** Contura III  
**E** Contura V  
**F** Contura V - Laser Etched  
**M** Contura XIV  
**N** Contura XIV - Laser Etched  
**R** Indicator/Blank Cap <sup>3</sup>  
**Z** No Rockers

 [Configure Complete Part Number >](#)

### 5. ORIENTATION <sup>4</sup> See orientation diagram page for more details

|          |               | Mounting Panel Thickness              |
|----------|---------------|---------------------------------------|
| <b>1</b> | Orientation 1 | 0.06 to 0.11 inches<br>[1.6 to 2.8mm] |
| <b>2</b> | Orientation 2 |                                       |
| <b>3</b> | Orientation 3 |                                       |
| <b>4</b> | Orientation 4 |                                       |
| <b>5</b> | Orientation 5 | 0.11 to 0.16 inches<br>[2.8 to 4.0mm] |
| <b>6</b> | Orientation 6 |                                       |
| <b>7</b> | Orientation 7 |                                       |
| <b>8</b> | Orientation 8 |                                       |

### 6. NETWORK TYPE

**1** 250K Baud Rate  
**2** 500K Baud Rate  
**4** 125K Baud Rate

### 7. SOURCE ADDRESS <sup>4</sup>

**000** A Unique Number (**0-238**)  
**000** A Unique Number (**0-127**) <sup>1</sup>

#### Notes:

- When CANopen is selected, the second listed '000' (Part 1, Box 7) must be selected.
- If any code besides Code Z is chosen, please configure all rockers using Part 3 of the ordering scheme (next page).
- Available with stationary Switch Circuit Code 8 only (Part 2, Box 1).
- The Source Address is a unique number (**000-238**) assigned to each node on a CAN network, and is determined based on the specific CAN architecture of each customer application.
- Available with Rocker Style Code R only (Part 1, Box 4).

## Part 2: Module Circuit and Lamps

Switch 1 to 3  
VM3 and VM6

**1 B 2 A - 2 A 1 0 - 6 0 0 0 -**

Selection 1 2 3 4 1 2 3 4 1 2 3 4

Switch 4 to 6  
VM6 Only

**1 B 2 A - 2 A 1 0 - 6 0 0 0**

Selection 1 2 3 4 1 2 3 4 1 2 3 4

### 1. SWITCH CIRCUIT

**1** 2 Position Maintained  
**2** 2 Position Momentary Top  
**3** 2 Position Momentary Bottom  
**4** 3 Position Momentary Bottom  
**5** 3 Position Maintained  
**6** 3 Position Momentary Top and Bottom  
**7** 3 Position Momentary Top  
**8** Stationary <sup>5</sup>

### 2. LAMP CIRCUIT

**A** L1 Backlight  
**B** L1, L2 Backlight  
**C** L2 Backlight  
**D** L1 Backlight, L2 Function Light  
**E** L1, L2 Function Light  
**F** L1 Function Light, L2 Backlight  
**G** L1 Function Light  
**H** L2 Function Light  
**O** No Lamp

### 3. LAMP 1

**1** LED 1, Red  
**2** LED 1, Green  
**3** LED 1, Blue  
**4** LED 1, Amber  
**5** LED 1, White  
**O** No LED

### 4. LAMP 2

**A** LED 2, Red  
**B** LED 2, Green  
**C** LED 2, Blue  
**D** LED 2, Amber  
**G** LED 2, White  
**O** No LED

# Ordering Scheme

## Part 3: Rockers

All Rocker options must match box 4 from part 1. For additional Contura® styles and options, consult factory.

### Contura II, III, V and XIV Rockers

Sample Part No. VV A Z C 00 - 0 00

Selection 1 2 3 4 5 6 7

#### 1. SERIES

**VV** V-Series Rocker

#### 2. ACTUATOR STYLE

**Contura II**  
**A** Thick end on top



**Contura III**  
**C** Thick end on top



**Contura V**  
**G** Contura V  
**P** Laser-Etched



**Contura XIV**  
**FA** Contura XIV  
**FB** Laser-Etched



#### 3. LENS

| Z - No Lens | Lens Style Location |       |       |       |     | Lens Style Location |     |     |   |                       |
|-------------|---------------------|-------|-------|-------|-----|---------------------|-----|-----|---|-----------------------|
|             | Clear               | White | Amber | Green | Red | Blue                | II  | III | V | XIV                   |
| 1           | 6                   | B     | G     | M     | T   |                     |     |     |   |                       |
| 2           | 7                   | C     | H     | N     | U   |                     |     |     |   |                       |
| 3           | 8                   | D     | J     | P     | V   |                     |     |     |   |                       |
| 4           | 9                   | E     | K     | R     | W   |                     | N/A |     |   |                       |
| 5           | A                   | F     | L     | S     | Y   |                     | N/A |     |   |                       |
| 5           | A                   | N/A   | N/A   | N/A   | N/A |                     |     |     |   | XIV laser-etched only |

#### 4. ACTUATOR COLOR AND TEXTURE

Contura II & III  
**B** Black **G** Gray **R** Red **W** White (Soft Surface)  
**C** Black **H** Gray **S** Red **Y** White (Hard Surface)

Contura V  
**C** Black **H** Gray **S** Red **Y** White  
**Laser-Etched only** **D** Nickel **E** Pewter

Contura XIV  
**C** Black **S** Red **Y** White

#### 5. ACTUATOR LENS OR BODY LEGENDS

**11** ON OFF **12** OFF ON **13** I O **14** O I

**15** O O F N **16** O O N F **17** O I F **18** I O

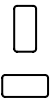

See standard legends codes page. Consult factory for additional icons.

#### 6. LEGEND ORIENTATION

**0** No legend (used with codes 11-18 in box 5)  
**1** Orientation 1  
**2** Orientation 2  
**3** Orientation 3  
**4** Orientation 4

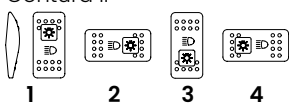
Contura II  

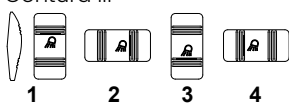
Contura III  

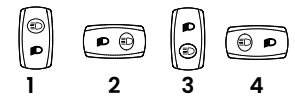
Contura V  

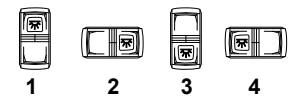
Contura XIV  

#### 7. ACTUATOR LENS LEGEND

**00** No legend this location (used with codes 11-18 in box 5) Box 7 required when rocker requires two legends. If the two legends consist of one lens and one body legend, lens legend must be specified in box 5; body legend specified in box 7.

See standard legends codes page. Consult factory for additional icons.

# Dimensional Specs

inches [millimeters]

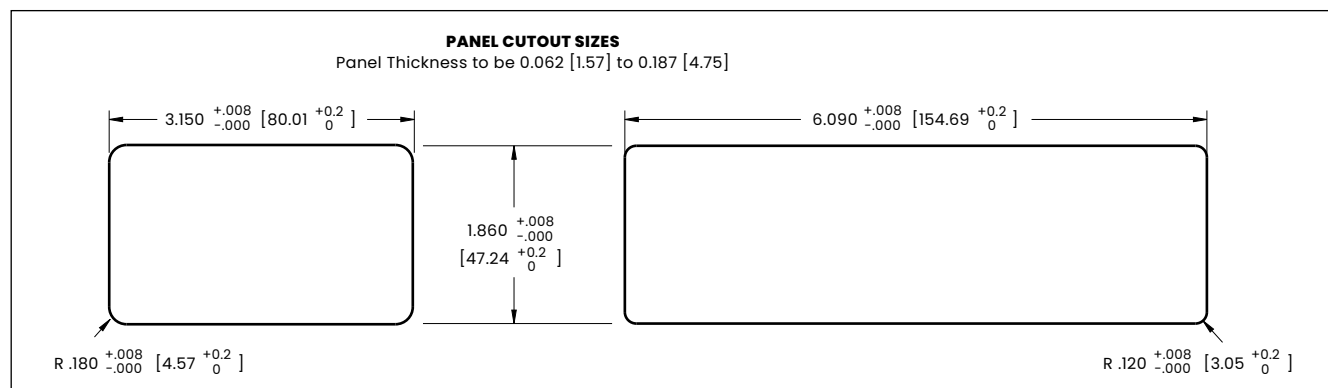
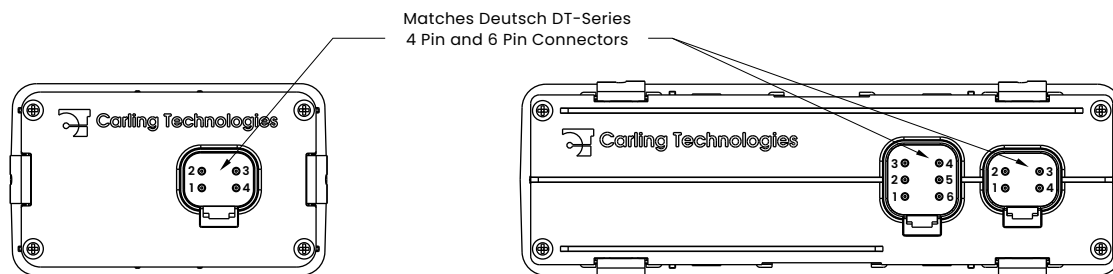
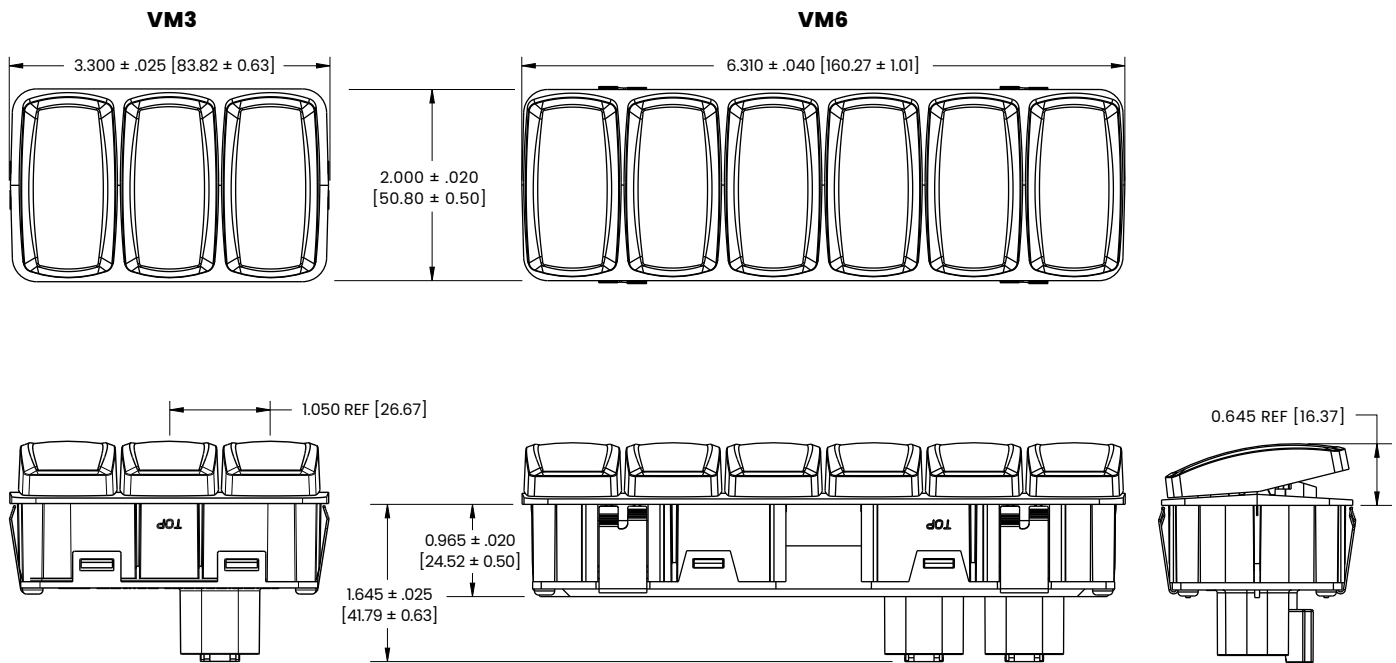

# Orientation Diagram

## Orientation 1

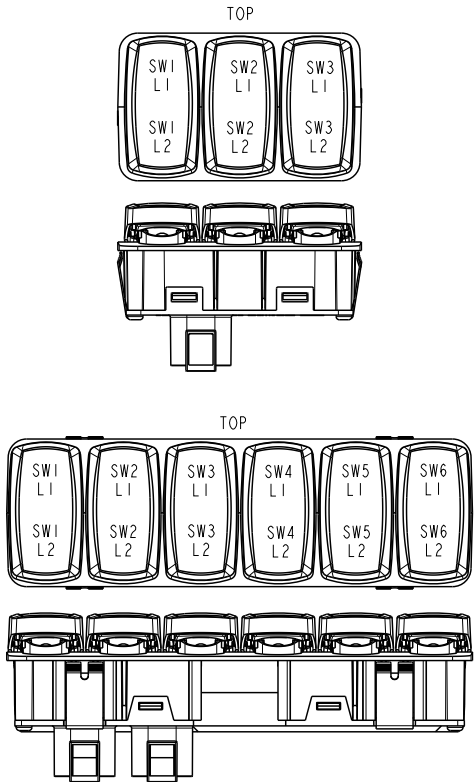

## Orientation 2

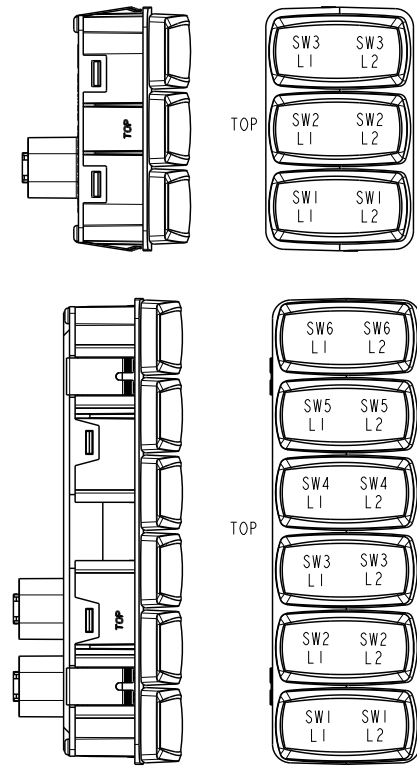

## Orientation 3

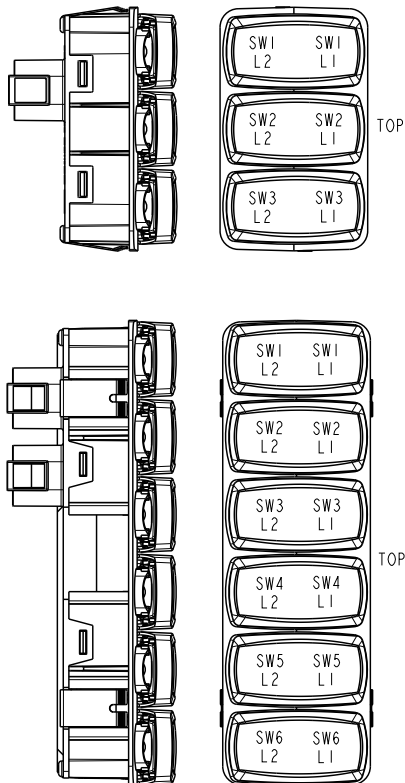

## Orientation 4

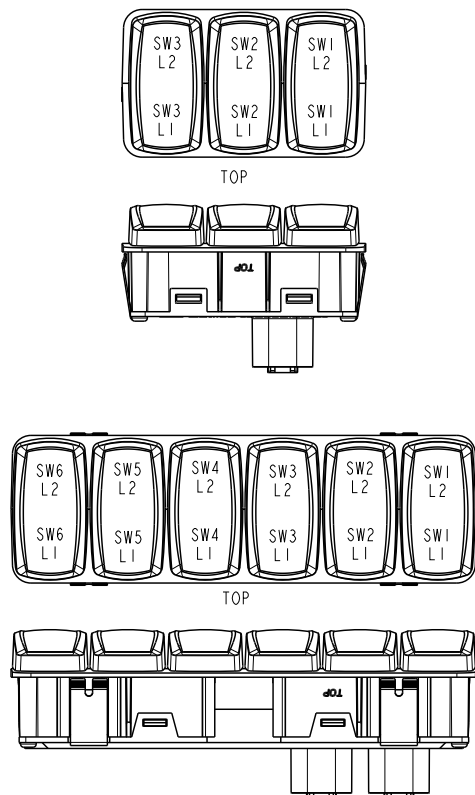

# Standard Legend Codes

|       |        |            |        |        |        |       |          |      |          |                 |           |      |
|-------|--------|------------|--------|--------|--------|-------|----------|------|----------|-----------------|-----------|------|
|       |        |            |        |        |        |       |          |      |          |                 |           |      |
| YK    | UA     | UB         | US     | UV     | UW     | UX    | UY       | MP   | MR       | PX              | MS        | MT   |
|       |        |            |        |        |        |       |          |      |          |                 |           |      |
| VU    | MW     | NZ         | NX     | NY     | YM     | VW    | PS       | PW   | PZ       | WG              | WM        | RN   |
|       |        |            |        |        |        |       |          |      |          |                 |           |      |
| RP    | YG     | TX         | VD     | VE     | VF     | VG    | SH       | SM   | SN       | SP              | SR        | SY   |
|       |        |            |        |        |        |       |          |      |          |                 |           |      |
| DIM   | BRIGHT | UH         | UJ     | PD     | PE     | PF    | VC       | VJ   | UF       | UG              | MU        | TN   |
|       |        |            |        |        |        |       |          |      |          |                 |           |      |
| WY    | WZ     | WIPER      | VZ     | YE     | NN     | RW    | PU       | WA   | YN       | UE              | NM        | RJ   |
|       |        |            |        |        |        |       |          |      |          |                 |           |      |
| NS    | PB     | SE         | VR     | SL     | VA     | UC    | VN       | PK   | VY       | HORN            | RH        | NU   |
|       |        |            |        |        |        |       |          |      |          |                 |           |      |
| NR    | YD     | TL         | VR     | SL     | VA     | UC    | VN       | PK   | VY       | UZ              | RH        | NU   |
|       |        |            |        |        |        |       |          |      |          |                 |           |      |
| NV    | RB     | RC         | RK     | RL     | MZ     | RG    | UP       | DOWN | UD       | UR              | WD        | TY   |
|       |        |            |        |        |        |       |          |      |          |                 |           |      |
| PA    | UK     | WATER PUMP | UU     | UT     | ANCHOR | PM    | VV       | WB   | TB       | TC              | TD        | TE   |
|       |        |            |        |        |        |       |          |      |          |                 |           |      |
| MY    | PV     | TA         | TZ     | WC     | PT     | PN    | PH       | RA   | TU       | TT              | YL        | SK   |
|       |        |            |        |        |        |       |          |      |          |                 |           |      |
| VS    | UL     | UM         | WK     | TS     | VT     | WL    | VP       | YJ   | PJ       | RY              | UP        | NW   |
|       |        |            |        |        |        |       |          |      |          |                 |           |      |
| NP    | RE     | RF         | PP     | PR     | TV     | PC    | YT       | YU   | PL       | WJ              | MV        | RR   |
|       |        |            |        |        |        |       |          |      |          |                 |           |      |
| TK    | RT     | SEAT       | VX     | WF     | WH     | PG    | SJ       | YA   | YB       | RM              | TM        | RD   |
|       |        |            |        |        |        |       |          |      |          |                 |           |      |
| RS    | UN     | TP         | TR     | NT     | MX     | YC    | TW       | TJ   | YF       | TH              | TF        | TG   |
|       |        |            |        |        |        |       |          |      |          |                 |           |      |
| YS    | YH     | AUX        | ON OFF | OFF ON | I O    | O I   | OFF ON   | ON   | OFF      | I               | O         | II   |
|       |        |            |        |        |        |       |          |      |          |                 |           |      |
| RAISE | LOWER  | HIGH       | LOW    | FWD    | REV    | DEPTH | TRIM TAB | ACC  | NAV ANCH | WIND LASS UP/DN | LIVE WELL | REAR |
|       |        |            |        |        |        |       |          |      |          |                 |           |      |
| ST    | SU     | WU         | WV     | SV     | SW     | VB    | VH       | VK   | VL       | VM              | WE        | SF   |
|       |        |            |        |        |        |       |          |      |          |                 |           |      |
| PARK  | AUTO   | RU         | RV     | RX     |        |       |          |      |          |                 |           |      |
|       |        |            |        |        |        |       |          |      |          |                 |           |      |
| SG    | SS     |            |        |        |        |       |          |      |          |                 |           |      |