

BATTERY

BATTERY MONITOR

A3680

The Battery Monitor is capable of measuring one (1) Current, two (2) DC Voltages, and up to four (4) individual battery temperatures. The Battery Monitor Cable Harness (P/N A2225-[], see Table 1 and 2) enables the monitor to connect to the batteries. The Battery Shunt 200 Amp, 50mV (P/N MS91587-2), is needed to measure the current that is installed on the high side of the installation. The Battery Monitor is NMEA 2000® certified, allowing the user to view all DC information over an NMEA 2000 network.



Product Highlights:

- ♦ Capable of Monitoring the following:
 - Current Measurement
 - Two (2) DC Voltage Measurements
 - Four (4) Temperature Measurements
- ♦ Configurable Alerts/Alarms
- ♦ Single CAN BUS Communication



Installation

The Battery Monitor was designed to be installed in a protected, non-explosive area of the vessel. Take precautions to install the Battery Monitor in an area that will be away from direct exposure to the weather and combustible fumes.

CAN Connections

One male Micro-C connectors is provided on the top of the Battery Monitor for connection to the primary CAN bus via drop cable.



NOTE

Use the shortest drop length possible when connecting the Battery Monitor to the CAN backbone. NMEA 2000 spec is maximum 6 meters for drop cables.

*Manufacturer reserves the right to change product specification without prior notice. Please refer to our website for the latest details.

Typical Installation Diagram

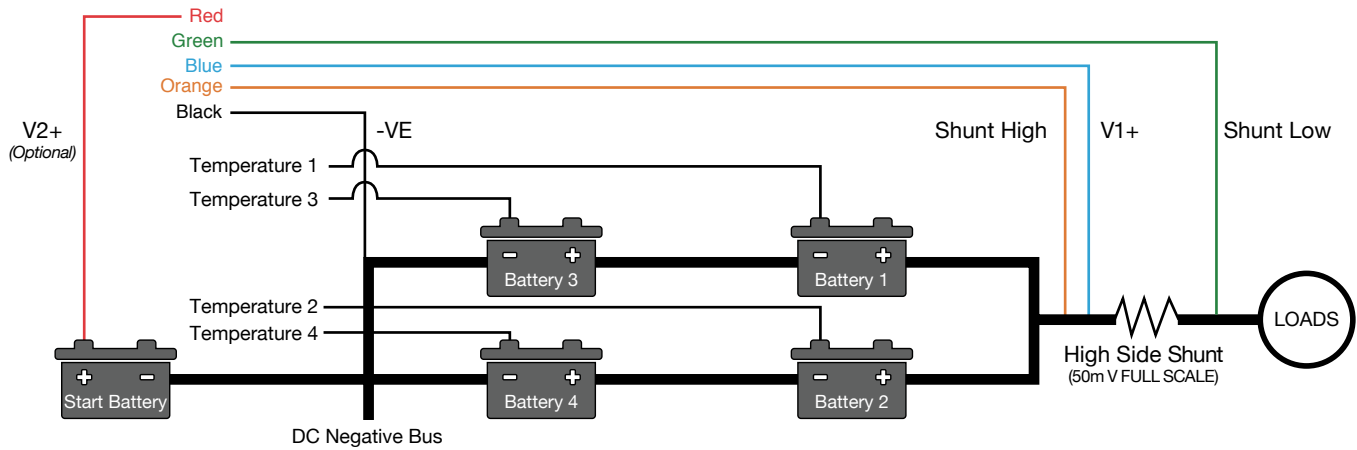

NOTE

Mount Temperature Sensors (Part of A2225-[]) to Battery stud or adhere directly to battery



CAUTION!

When no High Side Shunt is used, tie the orange, green and blue wires directly to the V1+ side of the battery. Installer must follow applicable industry standards i.e. ABYC/CE for properly wiring and utilizing external protective devices i.e. fuses as required.

Battery Monitor Harness Cable



Table 1:

Part Number	Description
A2225-4	Battery Monitor Cable Harness - 4'
A2225-6	Battery Monitor Cable Harness - 6'
A2225-8	Battery Monitor Cable Harness - 8'
A2225-14	Battery Monitor Cable Harness - 14'
A2225-16	Battery Monitor Cable Harness - 16'
MS91587-2	Battery Shunt 200Amp, 50mV

Table 2:

Pin	Connection	Color
1	Temperature Sensor 1 Signal	
2	Shunt High	Orange
3	Temperature Sensor 2 Signal	
4	Temperature Sensor 1 Ground	
5	Ground	Black
6	Shunt Low	Green
7	Temperature Sensor 3 Signal	
8	Temperature Sensor 3 Ground	
9	Temperature Sensor 2 Ground	
10	Reserved	
11	Battery V2+ 12-30VDC	Red
12	Temperature Sensor 4 Signal	
13	Temperature Sensor 4 Ground	
14	Reserved	
15	Not Used	
16	Not Used	
17	Not Used	
18	Battery V1+ 12-30VDC (Must be connected to power monitor)	Blue

Operation

The Battery Monitor has one (1) configurable parameter; the maximum current value of the high side shunt being used. This parameter is a factory setting. The voltage drop across the high side shunt should not exceed 50 mV for the configured current. For example, if the maximum shunt value selected is 200 amps, then the voltage drop across the high side shunt at 200 Amps should not exceed 50 mV DC.

Standard Battery Monitor Screen Layout

The Battery Monitor screen shows the status (voltage, current, temperature & state of charge) of the battery banks being monitored. Specific configuration and installation of the battery monitor is defined by the boat builder.



This page can vary between installations, as format is determined and/or customizable by the boat builder or owner.

NOTE

Maintenance

The Battery Monitor requires no maintenance. Any service or repair issues should be handled by a factory authorized technician.

General Specifications

Electrical

Power Input	12 VDC – 30VDC, 100 mA max (Blue Wire)
DC Voltage Input	12 VDC – 30VDC (Red Wire)
Shunt Voltage	50 mVDC (Orange/Green Wires)
CAN Bus Voltage	+15 VDC (± 0.5)
Load Equivalence Number (LEN)	1

Mechanical

Dimensions	5.50" X 2.43" X 2.43"
CAN Bus Connectors	One (1) Micro-C Male
Mounting	4 each 4 x 0.16 #6 hardware
Orientation	N/A

Certifications

NMEA 2000	Category B
Lloyd's Register	Lloyd's Type Approved, Test Specification #1, Env 2
CE	IEC 60533 Electrical and Electronic Installations in Ships IEC 60945 Maritime Navigation and Radio Communication Equipment and Systems

Environmental

Radiated, RF Field Immunity	IEC-61000-4-3
Electrical Fast Transient/Burst Immunity	IEC 61000-4-4
Voltage Surge Immunity	IEC 61000-4-5
Conducted, Immunity	IEC 61000-4-6
Conducted Emissions	IEC 60945
Voltage Variation Immunity	IEC 61000-4-11
Conducted LF Immunity	IEC 61000-4-16
ESD Immunity	IEC-61000-4-2
Insulation Resistance	IEC-60092-504
Operating Temperature	-40°C to +70°C
Storage Temperature	-40°C to +85°C
Temperature Sensor Range	-20°C to +70°C
Vibration	IEC-60068-2-6 Test Fc
Temperature Cycle	IEC 60945
Humidity	IEC-60068-2-30 Test Db
Corrosion	IEC 60945
Weight	0.75 lbs (0.34 kg) nominal

Dimensional Specifications: in [mm]

Battery Monitor A3680

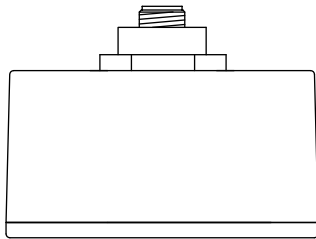
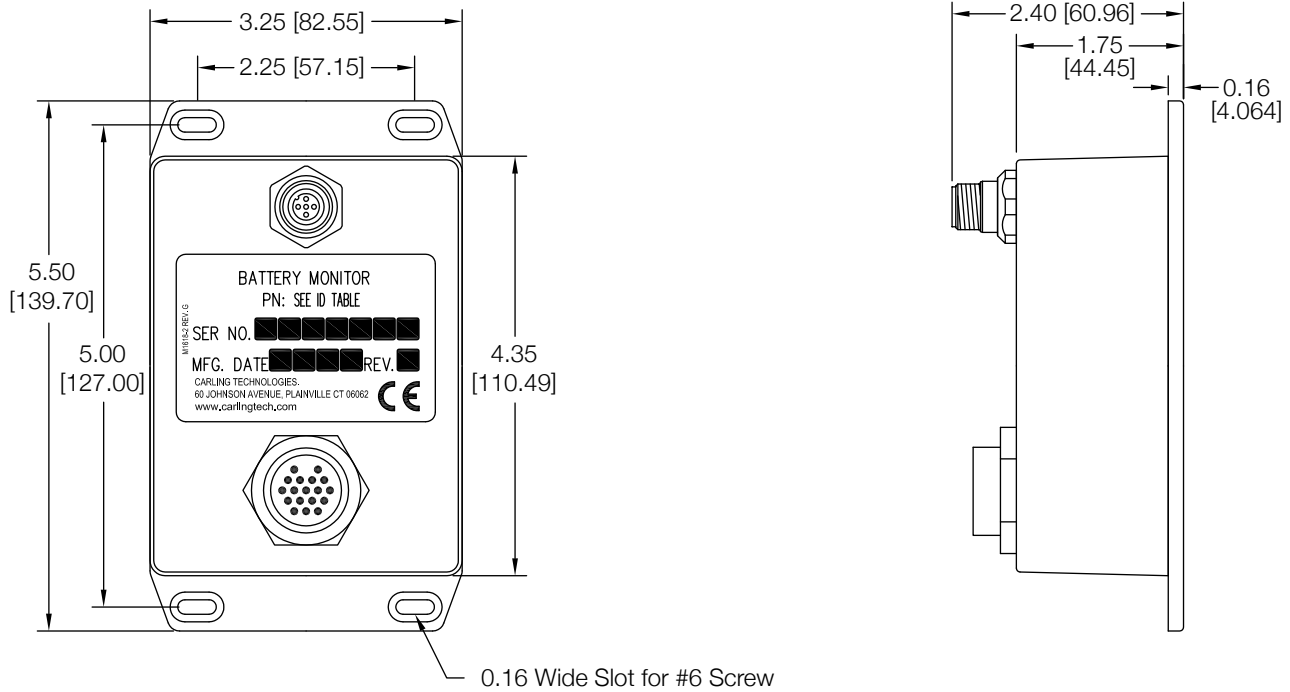

Shunt

Source: www.deltecco.com/MKB-DC.html

