

CRS-Series

Rotary Encoder Switch

[PRODUCT WEBPAGE](#)

request sample, configure part

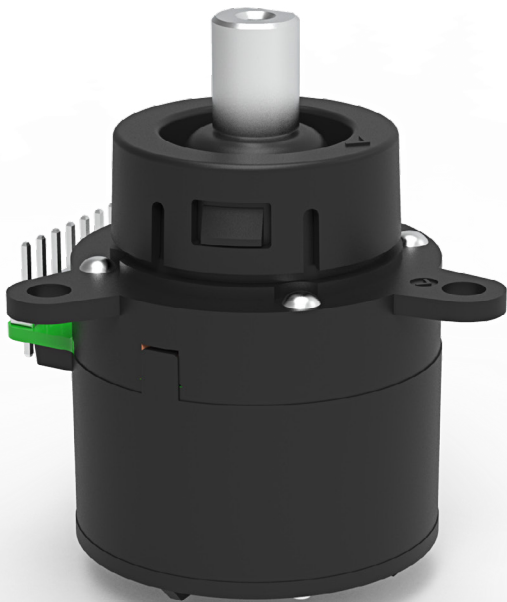

Rotary Encoder Switch Designed for Commercial Vehicles

The CRS-Series rotary encoder switch features an IP67 rating for above-panel components and mechanical and electrical endurance ratings of 500,000 cycles, making it ideal for work trucks, farm equipment, and construction vehicles. Available with an operating voltage rating of 3.3 V DC or 5.0 V DC, this rotary encoder switch is available for 4-way directional, rotary, and push-button input, rotary and push-button input, or rotary-only input.

** For a complete CAN solution, please see our CKJ-Series*

3.3 or 5.0 VDC **500,000 Cycles** **IP67 Sealing**
for above-panel components

Typical Applications

- Truck
- Bus
- Construction
- Mining
- Agricultural

Tech Specs

Electrical

Rotary

Supply current	20 mA maximum
Output	Open collector photo transistor. External pull-up resistors are required. See circuit schematic for external resistors.
Output code	2-bit quadrature, channel A leads channel B by 90° electrically during clockwise rotation of the shaft.
Minimum sink current	2.0 mA

Pushbutton

Contact resistance	Less than 0.2 ohm
Electrical endurance	Rotary; 500,000 cycles of one full rotation Push-button; 500,000 cycles Joystick; 500,000 cycles in each direction

Joystick

Output code	2-bit
-------------	-------

Environmental

Operating temperature	-40°C to + 85°C
Storage Temperature	-40°C to + 85°C
Thermal, Hot Soak	IEC 60068-2-2; Test Bb, + 85°C for 96 hours
Thermal, Cold Soak	IEC 60068-2-1; Test Ab, - 40°C for 96 hours
Thermal Shock	IEC 60068-2-14; Test Na, - 55°C to +100°C, 10 cycles for 10 hours
Sealing Protection	ISO 20653; IP67 above panel
Humidity, soak (Damp heat)	IEC 60068-2-78; Test Cab, 96 hours at 93% humidity and 40°C
Salt Spray	IEC 60068-2-11; Test Ka, 5% NaCl, spray for 48 hours
Thermal Cycling (Change of Temperature)	IEC 60068-2-14; Test Nb, -40°C to 85°C, dwell: 3 hours; transfer rate: (3 ± 0.6°C)/min, 2 cycles

Mechanical

Rotary

Lifecycle	500,000 rotational cycles of operation (one cycle is a rotation through all positions and a full return)
Average rotational torque	.038 ± .014 N-m [5.4 ± 2 oz-in] initially, rotation torque within 50% of initial value throughout life.

Pushbutton

Lifecycle	500,000 actuations
Actuation force	16 ± 3 N [3.6 ± .67 lbs]
Shaft travel	0.8 ± 0.3 mm [.031 ± .012 inches]

Joystick

Lifecycle	500,000 actuations in each direction
Actuation torque	0.18 ± 0.06 N-m [25.5 ± 8.5 oz-in]
Angle of throw	4° ± 2° in each direction
Vibration, Sinusoidal	MIL-STD 202G; Method 204, Condition B, sinus vibration harmonic motion with 1.5mm from 10Hz to 60Hz and 15g (peak) from 60Hz to 2000Hz. Each axis 4 hours total 12 hours.
Shock	MIL-STD 202G; Method 213B, Condition C, 100G for 6ms, three shocks in each direction shall be applied along the three mutually perpendicular axes of the test specimen (18 shocks)
Drop test	IEC 60068-2-31; Test Ee, FreeFall -Procedure 1 drop in each direction of the 3 axes {6 total drops) from 1m

Physical

Pin out terminal	Pin header, pin size .020 X .020 SQ, pitch .079 inch
Mounting	3x mounting holes
Mounting torque	1.2 - 1.4 N-m [10.62 - 12.39 inch-lbs]
Weight	25 grams [.055 lbs]
Materials	Seal Holder: Nylon Housing: Nylon Base: Nylon Bottom Cover: Nylon Seal: Silicone Shaft: Stainless steel Pin Out Terminal: Brass, gold plated Dome Contact: Stainless steel PCB:FR

Tech Specs

Tables

Rotary			
Operating Voltage (VDC)	"High" Logic Output (VDC)	"Low" Logic Output (VDC)	Maximum Power Consumption (MW)
5.00 ± .25	>3.5	< 1.0	100
3.30 ± .25	> 2.6	<.8	66

Pushbutton	
Operating Voltage (VDC)	Current Rating (MA)
5.00 ± .25	16
3.30 ± .25	12

Joystick				
Operating Voltage (VDC)	Maximum Supply Current (MA)	"Neutral" Logic Output (VDC)	"High" Logic Output (VDC)	"Low" Logic Output (VDC)
5.00 ± .25	0.6	2.5 ± 0.5	>4.5	<0.5
3.30 ± .25	0.4	1.65 ± 0.2	>= 3	<0.5

Joystick Truth Table		
Position	X Output	Y Output
1	Neutral	High
2	High	Neutral
3	Neutral	Low
4	Low	Neutral
Center	Neutral	Neutral

Rotary Switch Truth Table		
Clockwise Rotation		
Position	Output A	Output B
1	●	
2	●	
3		●
4		●

• Indicates logic high; blank indicates logic low.
Code repeats every 4 positions

Circuit Schematic & Joystick Operation

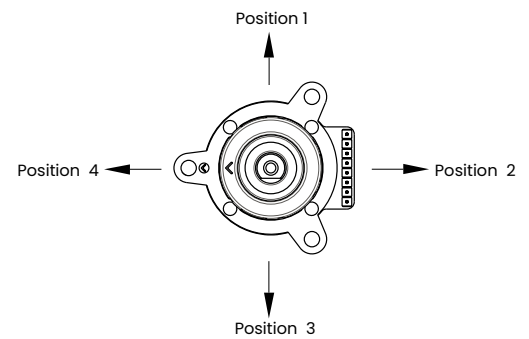
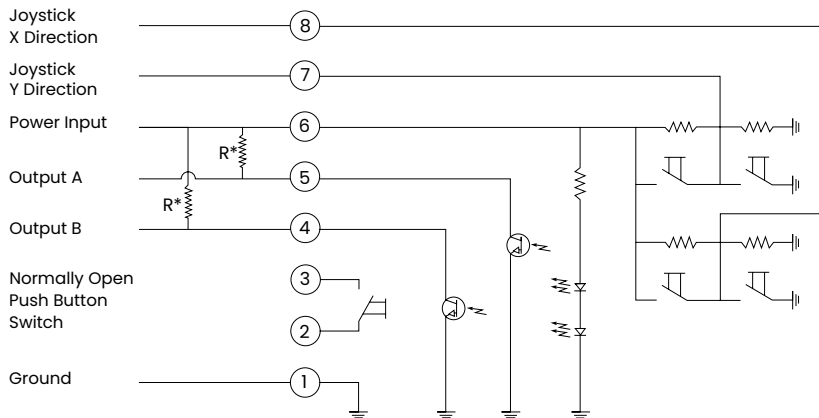

External Pull-up Resistors Required for Operation (2.2K½) When Operating Power is 5.0VDC
External Pull-up Resistors Required for Operation (3.0K½) When Operating Power is 3.3VDC

Rotary Switch Waveform

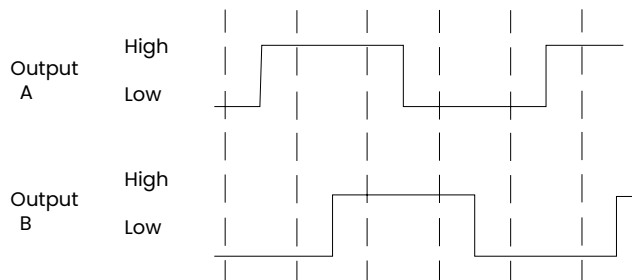

Ordering Scheme

Sample Part No. **CRS - 1 - 2 - 1**

Selection 1 2 3 4

1. SERIES

CRS Carling Rotary Encoder Switch

2. SWITCH INPUT TYPE/FUNCTION

- 1 Directional, Rotary and Push
- 2 Rotary and Push
- 3 Rotary Only

3. RATED VOLTAGE OF ROTARY OPERATION

- 1 5.0VDC
- 2 3.3VDC

4. TERMINATION

- 1 Pin Header

Dimensional Specs

inches [millimeters]

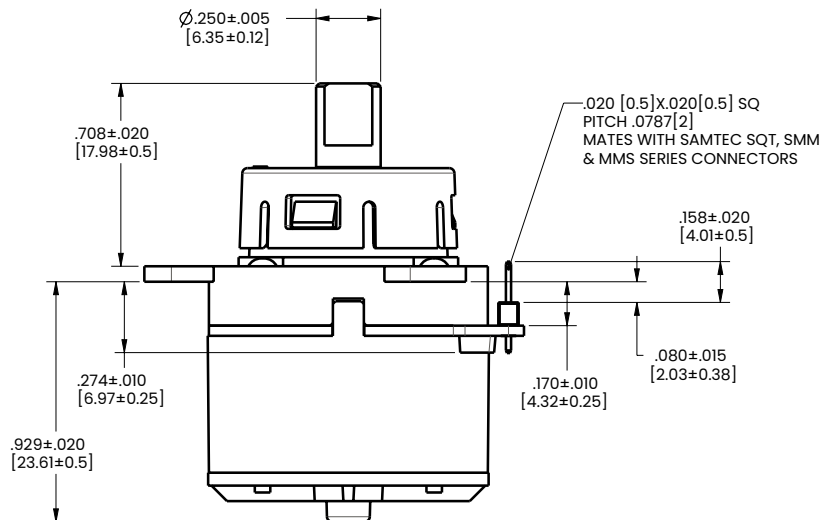
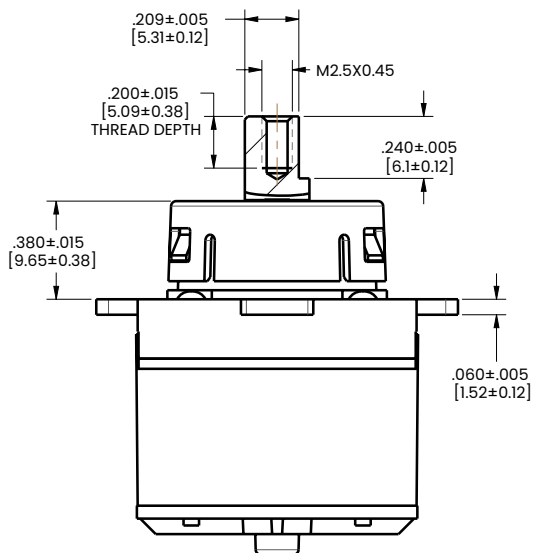
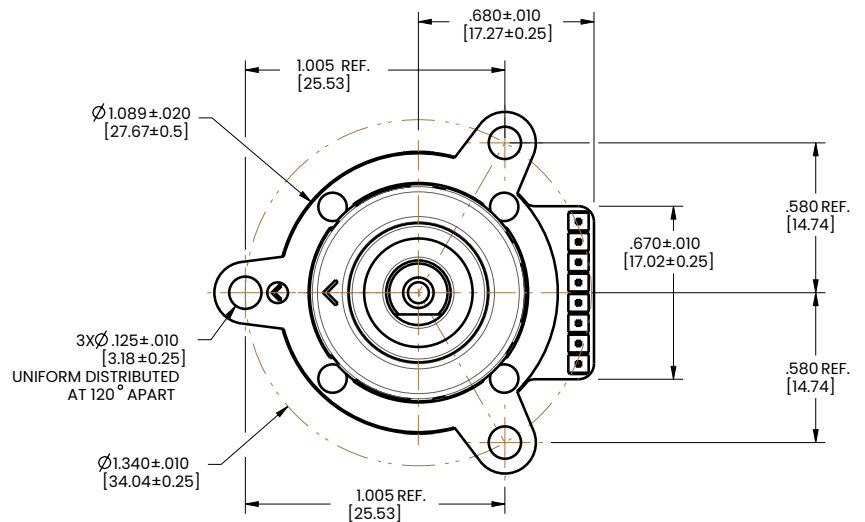
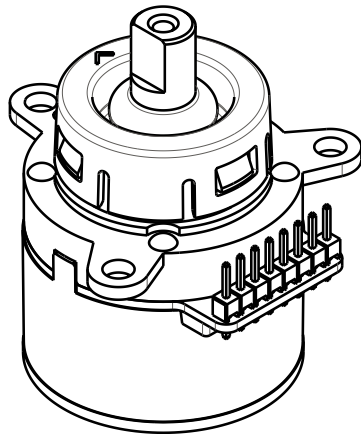

Authorized Sales Representatives and Distributors

Click on a region of the map below to find your local representatives and distributors or visit www.carlingtech.com/findarep.



About Carling

Founded in 1920, Carling Technologies is a leading manufacturer of electrical and electronic switches and assemblies, circuit breakers, electronic controls, power distribution units, and multiplexed power distribution systems. With six ISO9001 and IATF16949 registered manufacturing facilities and technical sales offices worldwide, Carling Technologies Sales, Service and Engineering teams do much more than manufacture electrical components, they engineer powerful solutions! To learn more about Carling please visit www.carlingtech.com/company-profile.

To view all of Carling's environmental, quality, health & safety certifications please visit www.carlingtech.com/environmental-certifications.

© Carling Technologies, Inc.

5. Carling is a registered trademark of Carling Technologies, Inc. in the U.S. and other countries.