

H-Series

Hydraulic-Magnetic Circuit Breaker

PRODUCT WEBPAGE

request sample, configure part



Compact and IEC Compliant for Global Markets

The H-Series is a compact hydraulic-magnetic circuit breaker, meeting IEC spacing requirements for global market applications. It features a “trip free” mechanism, which will open the contacts when a fault condition occurs, even if the handle is held in the ON position. It fits both general and full amp load conditions, offering a choice of terminal options and handle or rocker actuators. The H-Series is rated up to 35 amps with a maximum voltage of 250VAC/65VDC or 80VDC for single pole configurations and a max IC of 3,000 amps.

1-3	1-35	80	250
Poles	Amps	VDC Max	VAC Max

Typical Applications

- Datacom/Telecom
- Marine

Tech Specs

Electrical

Maximum Voltage	250VAC 50/60Hz 80 VDC
Current Ratings	Standard current coils: 1.00, 2.50, 5.00, 7.50, 10.0, 15.0, 20.0, 25.0, 30.0, 32.0, 35.0 SPDT: 10.1A-250VAC, Auxiliary Switch Rating 1.0A-65VDC/0.5A-80VDC,
Auxiliary Switch Rating	1.0A-65VDC/0.5A-80VDC, 0.1A-125VAC (with gold contacts)

Mechanical

Endurance	10,000 ON-OFF operations @ 6 per minute; with rated current & voltage
-----------	---

Physical

Number of poles	1-3
Weights	Approx. 48 grams/pole (1.7 oz)
Internal Circuit config.	Series and Switch Only (with or without auxiliary switch)

Agency Approvals

UL Recognized under the Component Recognition Program as Protectors, Supplementary (Guide QVNU2 File E75596)
UL standard 1077

CCC certified, Certificate No. 2010010307447291

CSA Accepted Supplementary Protector
CSA standard C22.2 No. 235

TUV certified to EN60934, Certificate No. R50204086

Resistance, Impedance Values

RESISTANCE, IMPEDANCE VALUES
from Line to Load Terminals
(Values Based on Series Trip Circuit Breaker)

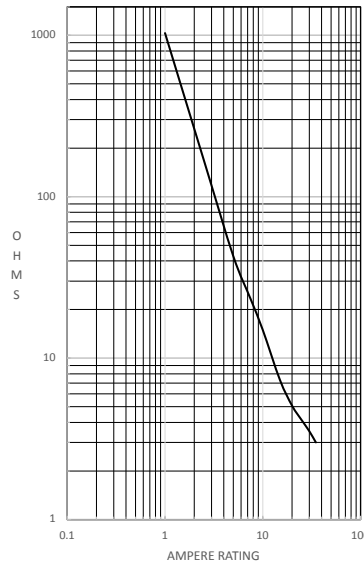

CURRENT (AMPS)	TOLERANCE (%)
1.0 - 10.0	+/- 25
10.1 - 35.0	+/- 35

Tables

Table A: Lists UL Recognized, CSA Accepted and TUV Certified configurations and performance capabilities as a Component Supplementary Protector.

Component Supplementary Protectors											
Circuit Configuration	Voltage			Current Rating		Minimum Poles	Short Circuit Capacity (Amps)			Application Codes	
	Max Rating	Frequency	Phase	Full Load Amps	Without Backup Fuse			UL	CSA		
					UL		CSA			TUV	
Series	65	DC	---	1 - 25	1	3000	3000	3000	TC1, OL1, U1	TC1, OL1, U1	
	65	DC	---	26 - 35	1	3000	3000	3000	TC1, OL1, U3	TC1, OL1, U3	
	80	DC	---	1 - 25	1	1000	1000	1000	TC1, OL1, U1	TC1, OL1, U1	
	80 ¹	DC	---	26 - 35	1	1000	1000	1000	TC1, OL1, U3	TC1, OL1, U3	
	250	50 / 60	1	1 - 35	1	1500	1500	500	TC1, OL1, U1	TC1, OL1, U3	
	250	50 / 60	1	1 - 35	2	1500	1500	500	TC1, OL1, U3	TC1, OL1, U3	
	250	50 / 60	3	1 - 35	3	1500	1500	500	TC1, OL0, U3	TC1, OL0, U3	

Notes:
1 Polarity Sensitive

Time Delay Specs

To view all hydraulic-magnetic circuit breaker time delay values, please visit www.carlingtech.com/sites/default/files/documents/Carling-HM-CB-Time-Delays.pdf

Ordering Scheme

Handle

Sample Part Number

H A 3 - B 0 - 24 - 420 - 1 B 1 - D C

Selection

1 2 3 4 5 6 7 8 9 10 11 12

1. SERIES

H

2. ACTUATOR 1

- A Handle, one per pole
- B Handle, one per unit

3. POLES 2

- 1 One
- 2 Two
- 3 Three

4. CIRCUIT

- A Switch Only (no coil)
- B Series Trip (current)
- C⁴ Series Trip (voltage)
- G⁴ Relay Trip (voltage)

5. AUXILIARY/ALARM SWITCH 3

- 0 without Aux Switch
- 1³ 0.110 Q.C. term
- 2³ 0.110 Solder Lug
- 3³ 0.110 Q.C. term
- 4³ 0.110 PC term

6. FREQUENCY & DELAY

- 03³ DC 50/60HZ, Switch Only
- 10 DC, Instantaneous
- 11 DC, Ultra Short
- 12 DC, Short
- 14 DC, Medium
- 16 DC, Long
- 20 50/60 Hz Instantaneous
- 21 50/60 Hz Ultra Short
- 22 50/60 Hz Short
- 24 50/60 Hz Medium
- 26 50/60 Hz Long
- 30 DC, 50/60Hz, Instantaneous
- 31 DC, 50/60Hz, Ultra Short
- 32 DC, 50/60Hz, Short
- 34 DC, 50/60Hz, Medium
- 36 DC, 50/60Hz, Long
- 42⁴ 50/60 Hz High-inrush Short
- 44⁴ 50/60 Hz High-inrush Medium
- 46⁴ 50/60 Hz High-inrush Long
- 52⁴ DC High-inrush Short
- 54⁴ DC High-inrush Medium
- 56⁴ DC High-inrush Long

7. CURRENT RATING (AMPERES)

CODE	AMPERES	
410	1.00	445 4.50
512	1.25	450 5.00
415	1.50	455 5.50
517	1.75	460 6.00
420	2.00	465 6.50
522	2.25	470 7.00
425	2.50	475 7.50
527	2.75	480 8.00
430	3.00	485 8.50
435	3.50	490 9.00
440	4.00	495 9.50
610	10.00	710 10.50
618	18.00	711 11.50
620	20.00	712 12.00
622	22.00	713 13.00
624	24.00	714 14.00
625	25.00	715 15.00
630	30.00	716 16.00
632	32.00	717 17.00
635	35.00	

VOLTAGE RATING

CODE	RATING	TRIP VOLTS
A06	6DC	5DC
A12	12DC	10DC
A18	18DC	15DC
A24	24DC	20DC
A32	32DC	25DC
A48	48DC	40DC
A65	65DC	55DC
J06	6AC	5AC
J12	12AC	10AC
J18	18AC	15AC
J24	24AC	20AC
J48	48AC	40AC
J65	65AC	55AC
K20	120AC	65AC
L40	240AC	130AC
B10	110DC	59DC
B20	120DC	65DC

8. TERMINAL

- 1 Push ON 0.250 Tab (Q.C.)
- 2 Screw 8-32 with upturned lugs
- 3 Screw 8-32 (bus type)
- A Screw M4 with upturned lugs
- B Screw M4 (bus type)
- Printed Circuitboard Terminals**
- L 90 Facing Left
- R 90 Facing Right
- S Straight
- T Straight, Long

9. ACTUATOR COLOR & LEGEND

Actuator Color	I-O	ON-OFF	Dual	Legend Color
White	A	B	1	Black
Black	C	D	2	White
Red	F	G	3	White
Green	H	J	4	White
Blue	K	L	5	White
Yellow	M	N	6	Black
Gray	P	Q	7	Black
Orange	R	S	8	Black

10. MOUNTING / BARRIERS

	MOUNTING STYLE	BARRIERS	BEZEL
	Threaded Insert		
1	6-32 x 0.195 inches	no	domed
A	6-32 x 0.195 inches	yes	domed
2	ISO M3 x 5mm	no	domed
B	ISO M3 x 5mm	yes	domed
3	6-32 x 0.195 inches	no	flat
C	6-32 x 0.195 inches	yes	flat
4	ISO M3 x 5mm	no	flat
D	ISO M3 x 5mm	yes	flat

11. MAX. APPLICATION RATING

- A 65VDC
- D 250VAC
- M⁶ 80VDC
- 4⁷ 80VDC / 250VAC

12. AGENCY APPROVAL

- A Without approvals
- C UL Recognized, CSA Accepted
- E UL Recognized, CSA Accepted, TUV Certified
- 5 UL Recognized, CSA Accepted, TUV Certified, CCC Certified

Notes:

- 1 Actuator Option A: handle tie pin, spacer & retainers provided unassembled on multipole units.
Actuator Option B: Handle location as viewed from front of panel: 2 pole: left pole;
3 pole: center pole
- 2 Standard multipole units have all poles identical, except when specifying auxiliary switch
- 3 Auxiliary switch available on Series Trip and Switch Only circuits to 32A. On multipole units, only one auxiliary switch is normally supplied, mounted in extreme right pole.
- 4 Separate Pole Type Voltage Coils not rated for continuous duty. Available only with delay code 10 & 20. Only Available with Agency code C.
- 5 For other current ratings, consult factory.
- 6 26-35A Polarity sensitive, only available as 1 pole unit.
- 7 Voltage code 4 available to 25A max.

[Configure Complete Part Number >](#)

[Browse Standard Parts >](#)

Dimensional Specs Handle

inches [millimeters]

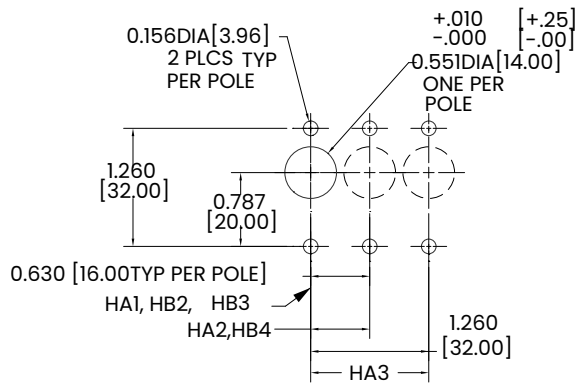
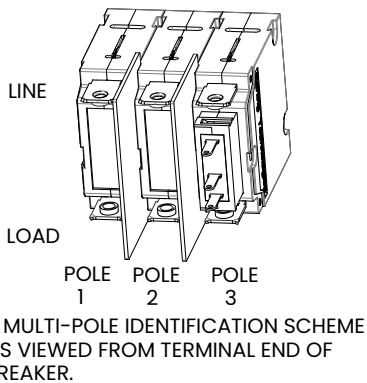
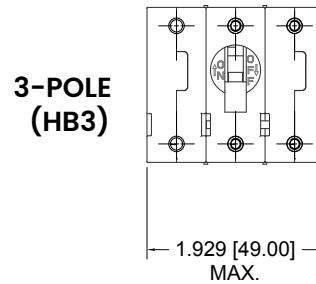
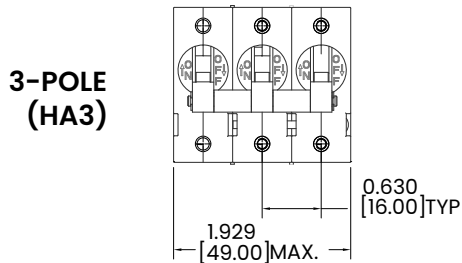
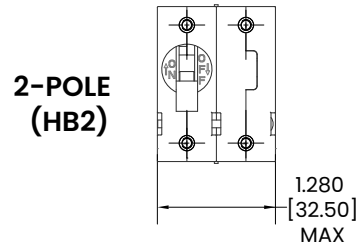
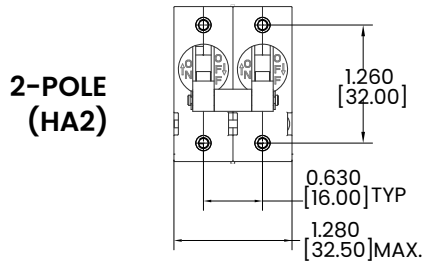
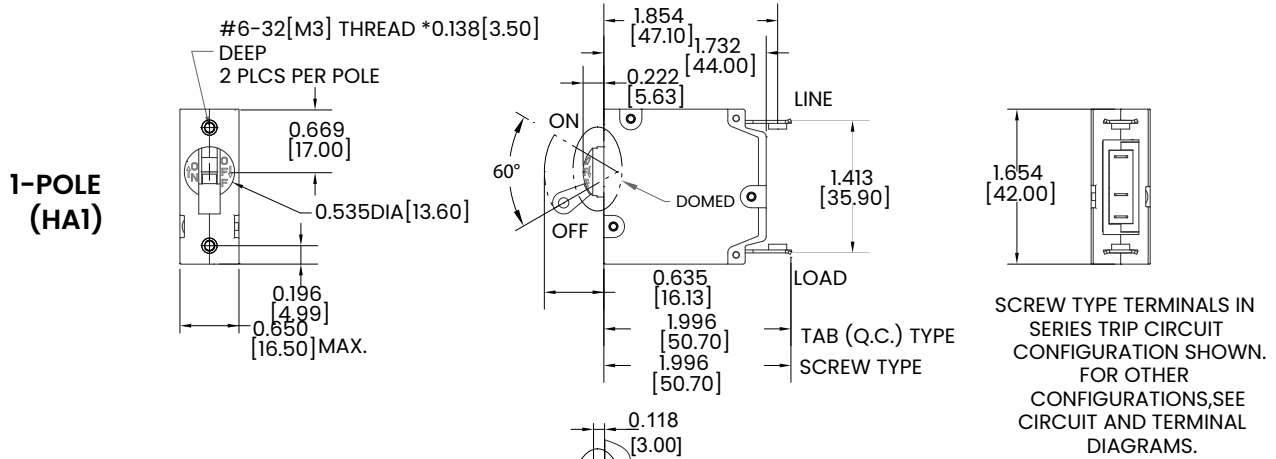

PANEL CUTOUT DETAIL
TOLERANCES ±.005
[±.12]
UNLESS OTHERWISE SPECIFIED

Notes:
1 Tolerance ±.020 [.51] unless otherwise specified.

PC Terminal Diagrams

Handle

inches [millimeters]

**PRINTED CIRCUIT BOARD
MOUNTING TERMINAL CODE R**

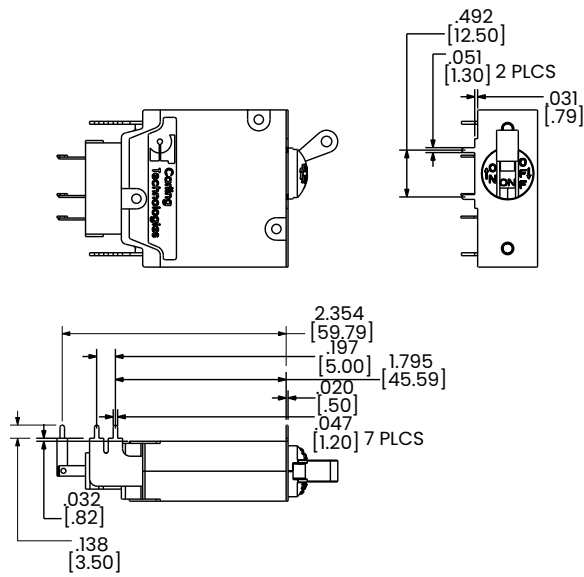

**PRINTED CIRCUIT BOARD
MOUNTING TERMINAL CODE L**

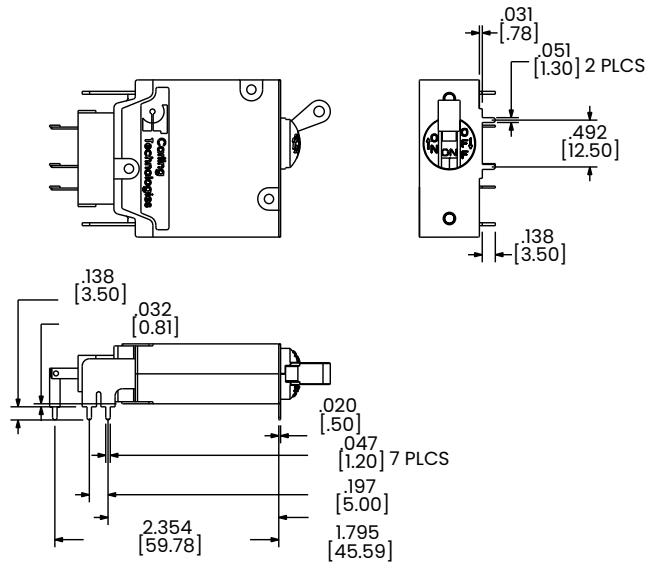

**PRINTED CIRCUIT BOARD MOUNTING
TERMINAL CODE S & T**

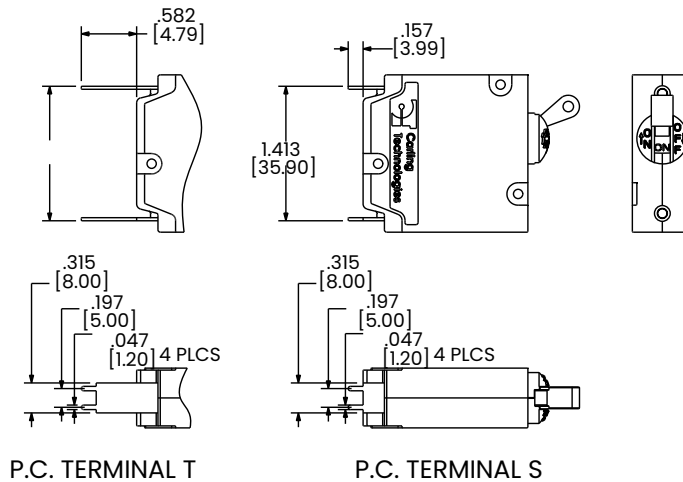

Notes:
1 Tolerance $\pm .020$ [.51] unless otherwise specified.

PC Terminal Diagrams

Handle

inches [millimeters]

P.C. FOOT PRINT FOR TERMINAL CODE R

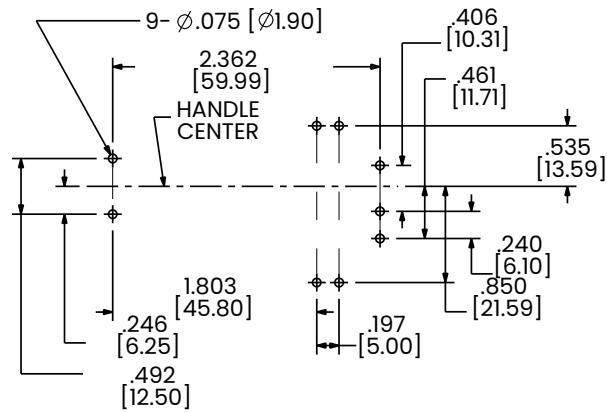

P.C. FOOT PRINT FOR TERMINAL CODE L

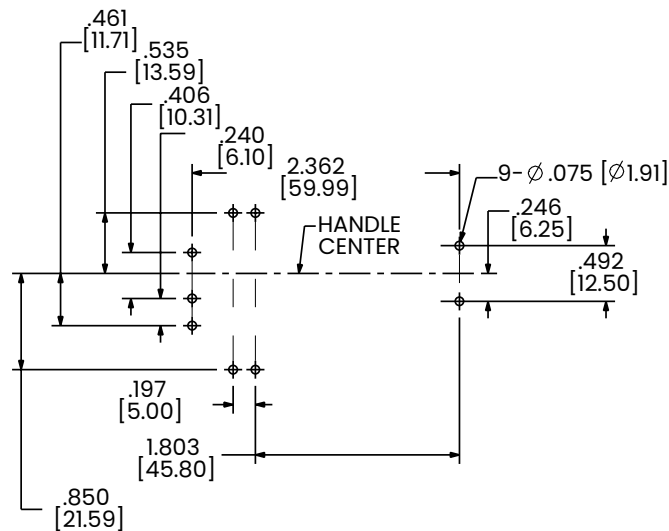

P.C. FOOT PRINT FOR TERMINAL CODE S & T

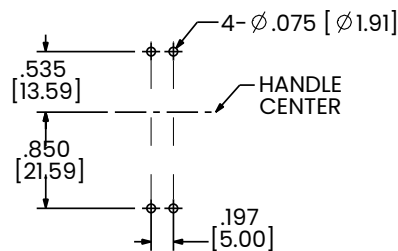

Notes:
1 Tolerance $\pm .020$ [.51] unless otherwise specified.

Ordering Scheme

Curved Rocker

Sample Part Number **H J 3 - B 0 - 10 - 450 - 1 B 1 - A C**

Selection 1 2 3 4 5 6 7 8 9 10 11 12

1. SERIES

H

2. ACTUATOR ¹

J Vertical - Indicator OFF
 K Vertical - Indicator ON
 L Horizontal - Indicator OFF
 M Horizontal - Indicator ON

3. POLES ²

1 One 2 Two 3 Three

4. CIRCUIT

A Switch Only (no coil) C⁴ Series Trip (voltage)
 B Series Trip (current) G⁴ Relay Trip (voltage)

5. AUXILIARY/ALARM SWITCH

0 without Aux Switch 3³ 0.110 Q.C. term
 1³ 0.110 Q.C. term with gold contacts
 2³ 0.110 Solder Lug 4³ 0.110 PC term

6. FREQUENCY & DELAY

03 ³ DC 50/60HZ, Switch Only	31 DC, 50/60Hz,Ultra Short
10 DC, Instantaneous	32 DC, 50/60Hz, Short
11 DC, Ultra Short	34 DC, 50/60Hz, Medium
12 DC, Short	36 DC, 50/60Hz, Long
14 DC, Medium	42 ⁴ 50/60 Hz High-inrush Short
16 DC, Long	44 ⁴ 50/60 Hz High-inrush Me- dium
20 50/60 Hz Instantaneous	46 ⁴ 50/60 Hz High-inrush Long
21 50/60 Ultra Short	52 ⁴ DC High-inrush Short
22 50/60 Hz Short	54 ⁴ DC High-inrush Medium
24 50/60 Hz Medium	56 ⁴ DC High-inrush Long
26 50/60 Hz Long	
30 DC, 50/60Hz, Instantaneous	

7. CURRENT RATING (AMPERES)

CODE	AMPERES							
410	1.00	445	4.50	610	10.00	618	18.00	
512	1.25	450	5.00	710	10.50	620	20.00	
415	1.50	455	5.50	611	11.00	622	22.00	
517	1.75	460	6.00	711	11.50	624	24.00	
420	2.00	465	6.50	612	12.00	625	25.00	
522	2.25	470	7.00	712	12.50	630	30.00	
425	2.50	475	7.50	613	13.00	632	32.00	
527	2.75	480	8.00	614	14.00	635	35.00	
430	3.00	485	8.50	615	15.00			
435	3.50	490	9.00	616	16.00			
440	4.00	495	9.50	617	17.00			

VOLTAGE RATING

CODE	RATING	TRIP VOLTS						
A06	6DC	5DC	A65	65DC	55DC	J65	65AC	55AC
A12	12DC	10DC	J06	6AC	5AC	K20	120AC	65AC
A18	18DC	15DC	J12	12AC	10AC	L40	240AC	130AC
A24	24DC	20DC	J18	18AC	15AC	B10	110DC	59DC
A32	32DC	25DC	J24	24AC	20AC	B20	120DC	65DC
A48	48DC	40DC	J48	48AC	40AC			

Notes:

- Half guard construction have OFF protection for actuator
- Standard multipole units have all poles identical, except when specifying auxiliary switch
- Auxiliary switch available on Series Trip and Switch Only circuits to 32A. On multipole units, only one auxiliary switch is normally supplied, mounted in extreme right pole.
- Separate Pole Type Voltage Coils not rated for continuous duty. Available only with delay code 10 & 20. Only Available with Agency code C.
- For other current ratings, consult factory.
- On Visi-Rocker, Visi portion of rocker cannot be the same color as the bezel. Remainder of rocker same color as bezel.
- 26-35A Polarity sensitive, only available as 1 pole unit.
- Voltage code 4 available to 25A max.

8. TERMINAL

1 Push ON 0.250 Tab (Q.C.)
 2 Screw 8-32 with upturned lugs
 3 Screw 8-32 (bus type)
 A Screw M4 with upturned lugs
 B Screw M4 (bus type)
Printed Circuitboard Terminals
 L 90 Facing Left
 R 90 Facing Right
 S Straight
 T Straight, Long

9. ACTUATOR COLOR & LEGEND

Actuator Color	I-O	ON-OFF	Dual	Legend Color
White	A	B	1	Black
Black	C	D	2	White
Red	F	G	3	White
Green	H	J	4	White
Blue	K	L	5	White
Yellow	M	N	6	Black
Gray	P	Q	7	Black
Orange	R	S	8	Black

10. MOUNTING / BARRIERS

	MOUNTING STYLE Threaded Insert	BARRIERS	ROCKER GUARD	BRACKET COLOR
1	6-32 x 0.195 inches	no	no	Black
A	6-32 x 0.195 inches	yes	no	Black
2	ISO M3 x 5mm	no	no	Black
B	ISO M3 x 5mm	yes	no	Black
3	6-32 x 0.195 inches	no	yes	Black
C	6-32 x 0.195 inches	yes	yes	Black
4	ISO M3 x 5mm	no	yes	Black
D	ISO M3 x 5mm	yes	yes	Black
5	6-32 x 0.195 inches	no	no	White
E	6-32 x 0.195 inches	yes	no	White
6	ISO M3 x 5mm	no	no	White
F	ISO M3 x 5mm	yes	no	White
7	6-32 x 0.195 inches	no	yes	White
G	6-32 x 0.195 inches	yes	yes	White
H	ISO M3 x 5mm	no	yes	White
8	ISO M3 x 5mm	yes	yes	White
9	6-32 x 0.195 inches	no	no	Gray
J	6-32 x 0.195 inches	yes	no	Gray
P	ISO M3 x 5mm	no	no	Gray
K	ISO M3 x 5mm	yes	no	Gray
Q	6-32 x 0.195 inches	no	yes	Gray
L	6-32 x 0.195 inches	yes	yes	Gray
U	ISO M3 x 5mm	no	yes	Gray
M	ISO M3 x 5mm	yes	yes	Gray

11. MAX. APPLICATION RATING

A 65VDC
 D 250VAC
 M⁷ 80VDC
 4⁸ 80VDC / 250VAC

12. AGENCY APPROVAL

A Without approvals
 C UL Recognized, CSA Accepted
 E UL Recognized, CSA Accepted, TUV Certified
 5 UL Recognized, CSA Accepted, TUV Certified, CCC Certified

Configure Complete Part Number >

Browse Standard Parts >

Ordering Scheme

Flat Rocker

Sample Part Number

H 3 3 - B 0 - 10 - 450 - 1 B 1 - A C

Selection 1 2 3 4 5 6 7 8 9 10 11 12

1. SERIES

H

2. ACTUATOR 1

- 3 Single Color Vertical
- 4 Single Color Horizontal
- 7 Push-to-Reset, Single Color Vertical
- 8 Push-to-Reset, Single Color Horizontal

3. POLES 2

1 One 2 Two 3 Three

4. CIRCUIT

- A Switch Only (no coil) C⁴ Series Trip (voltage)
- B Series Trip (current) G⁴ Relay Trip (voltage)

5. AUXILIARY/ALARM SWITCH

- 0 without Aux Switch 3³ 0.110 Q.C. term
- 1³ 0.110 Q.C. term with gold contacts
- 2³ 0.110 Solder Lug 4³ 0.110 PC term

6. FREQUENCY & DELAY

- | | |
|---|---|
| 03 ³ DC 50/60HZ, Switch Only | 31 DC, 50/60Hz, Ultra Short |
| 10 DC, Instantaneous | 32 DC, 50/60Hz, Short |
| 11 DC, Ultra Short | 34 DC, 50/60Hz, Medium |
| 12 DC, Short | 36 DC, 50/60Hz, Long |
| 14 DC, Medium | 42 ⁴ 50/60 Hz High-inrush Short |
| 16 DC, Long | 44 ⁴ 50/60 Hz High-inrush Medium |
| 20 50/60 Hz Instantaneous | 46 ⁴ 50/60 Hz High-inrush Long |
| 21 50/60 Ultra Short | 52 ⁴ DC High-inrush Short |
| 22 50/60 Hz Short | 54 ⁴ DC High-inrush Medium |
| 24 50/60 Hz Medium | 56 ⁴ DC High-inrush Long |
| 26 50/60 Hz Long | |
| 30 DC, 50/60Hz, Instantaneous | |

7. CURRENT RATING (AMPERES)

CODE	AMPERES	
410	1.00	445 4.50
512	1.25	450 5.00
415	1.50	455 5.50
517	1.75	460 6.00
420	2.00	465 6.50
522	2.25	470 7.00
425	2.50	475 7.50
527	2.75	480 8.00
430	3.00	485 8.50
435	3.50	490 9.00
440	4.00	495 9.50
610	10.00	618 18.00
710	10.50	620 20.00
611	11.00	622 22.00
711	11.50	624 24.00
612	12.00	625 25.00
712	12.50	630 30.00
613	13.00	632 32.00
614	14.00	635 35.00
615	15.00	
616	16.00	
617	17.00	

VOLTAGE RATING

CODE	RATING	TRIP VOLTS
A06	6DC	5DC
A12	12DC	10DC
A18	18DC	15DC
A24	24DC	20DC
A32	32DC	25DC
A48	48DC	40DC
A65	65DC	55DC
J06	6AC	5AC
J12	12AC	10AC
J18	18AC	15AC
J24	24AC	20AC
J48	48AC	40AC
J65	65AC	55AC
K20	120AC	65AC
L40	240AC	130AC
B10	110DC	59DC
B20	120DC	65DC
X01	65AC	special catalog #

Notes:

- 1 Push-To-Reset actuator shave OFF portion of rocker shrouded
- 2 Standard multipole units have all poles identical, except when specifying auxiliary switch
- 3 Auxiliary switch available on Series Trip and Switch Only circuits to 32A. On multipole units, only one auxiliary switch is normally supplied, mounted in extreme right pole
- 4 Separate Pole Type Voltage Coils not rated for continuous duty. Available only with delay code 10 & 20. Only Available with Agency code C.
- 5 For other current ratings, consult factory.
- 6 On Visi-Rocker, Visi portion of rocker cannot be the same color as the bezel. Remainder of rocker same color as bezel.
- 7 26-35A Polarity sensitive, only available as 1 pole unit.
- 8 Voltage code 4 available to 25A max.

8. TERMINAL

- 1 Push ON 0.250 Tab (Q.C.)
 - 2 Screw 8-32 with upturned lugs
 - 3 Screw 8-32 (bus type)
 - A Screw M4 with upturned lugs
 - B Screw M4 (bus type)
- Printed Circuitboard Terminals**
- L 90 Facing Left
 - R 90 Facing Right
 - S Straight
 - T Straight, Long

9. ACTUATOR COLOR & LEGEND

Actuator Color	I-O	ON-OFF	Dual	Legend Color
White	A	B	1	Black
Black	C	D	2	White
Red	F	G	3	White
Green	H	J	4	White
Blue	K	L	5	White
Yellow	M	N	6	Black
Gray	P	Q	7	Black
Orange	R	S	8	Black

10. MOUNTING / BARRIERS

	MOUNTING STYLE	BARRIERS	PUSH-TO-RESET	BRACKET COLOR
	Threaded Insert			
1	6-32 x 0.195 inches	no	no	Black
A	6-32 x 0.195 inches	yes	no	Black
2	ISO M3 x 5mm	no	no	Black
B	ISO M3 x 5mm	yes	no	Black
3	6-32 x 0.195 inches	no	yes	Black
C	6-32 x 0.195 inches	yes	yes	Black
4	ISO M3 x 5mm	no	yes	Black
D	ISO M3 x 5mm	yes	yes	Black
5	6-32 x 0.195 inches	no	no	White
E	6-32 x 0.195 inches	yes	no	White
6	ISO M3 x 5mm	no	no	White
F	ISO M3 x 5mm	yes	no	White
7	6-32 x 0.195 inches	no	yes	White
G	6-32 x 0.195 inches	yes	yes	White
8	ISO M3 x 5mm	no	yes	White
H	ISO M3 x 5mm	yes	yes	White
9	6-32 x 0.195 inches	no	no	Gray
J	6-32 x 0.195 inches	yes	no	Gray
P	ISO M3 x 5mm	no	no	Gray
K	ISO M3 x 5mm	yes	no	Gray
Q	6-32 x 0.195 inches	no	yes	Gray
L	6-32 x 0.195 inches	yes	yes	Gray
U	ISO M3 x 5mm	no	yes	Gray
M	ISO M3 x 5mm	yes	yes	Gray

11. MAX. APPLICATION RATING

- A 65VDC
- D 250VAC
- M⁷ 80VDC
- 4⁸ 80VDC / 250VAC

12. AGENCY APPROVAL

- A Without approvals
- C UL Recognized, CSA Accepted
- E UL Recognized, CSA Accepted, TUV Certified
- 5 UL Recognized, CSA Accepted, TUV Certified, CCC Certified

Configure Complete Part Number >

Browse Standard Parts >

Dimensional Specs Curved Rocker

inches [millimeters]

1-POLE (HJ1)

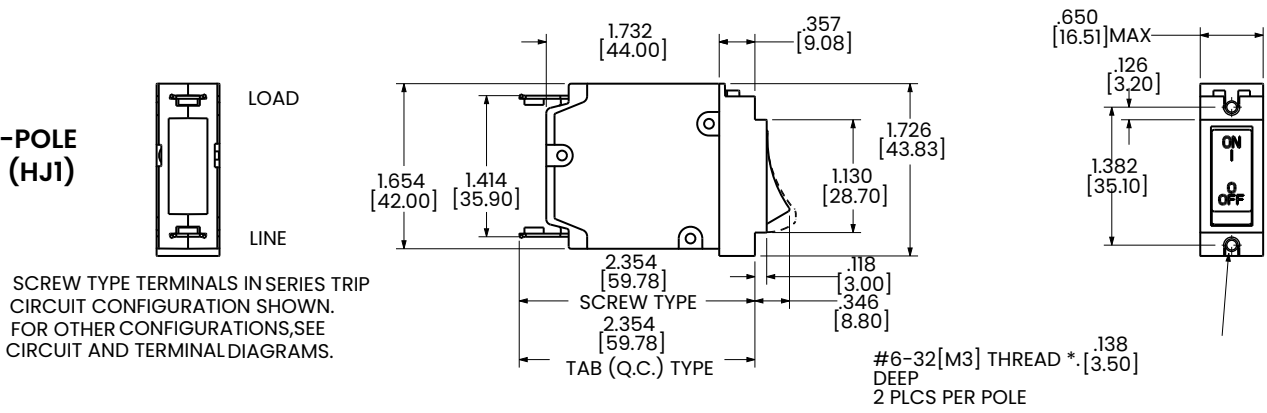

SCREW TYPE TERMINALS IN SERIES TRIP CIRCUIT CONFIGURATION SHOWN. FOR OTHER CONFIGURATIONS, SEE CIRCUIT AND TERMINAL DIAGRAMS.

2-POLE (HJ2)

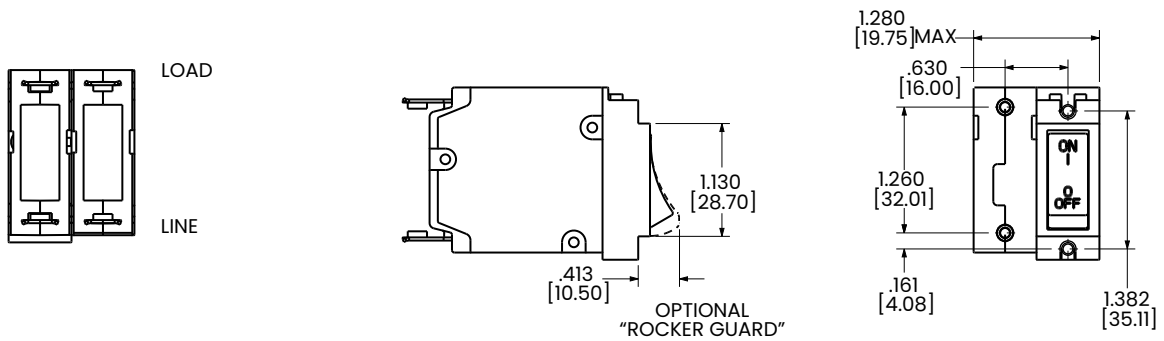

3-POLE (HJ3)

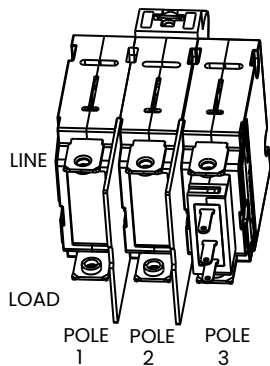
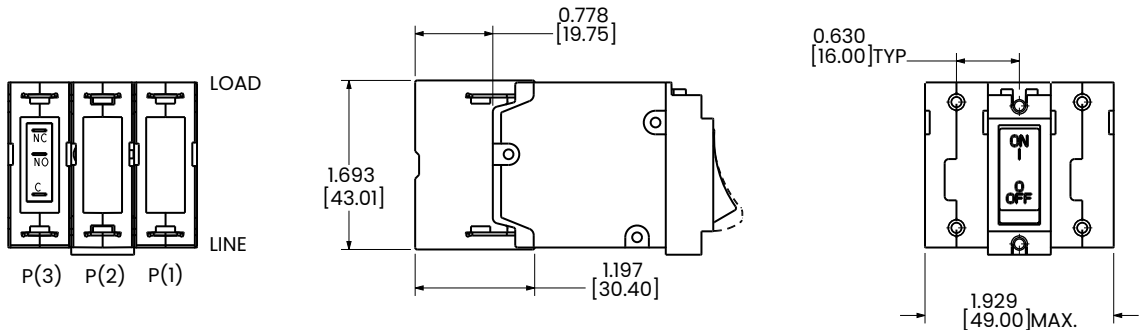

MULTI-POLE IDENTIFICATION SCHEME AS VIEWED FROM TERMINAL END OF BREAKER.

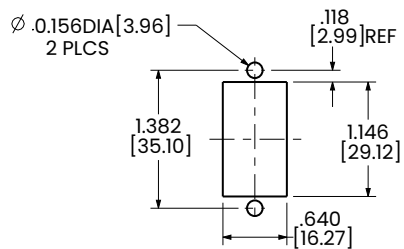

PANEL CUTOUT DETAIL
TOLERANCES ±.005 [±.12]
UNLESS OTHERWISE SPECIFIED

Notes:

1 Tolerance ±.020 [.51] unless otherwise specified.

Dimensional Specs Flat Rocker

inches [millimeters]

1-POLE (H31)

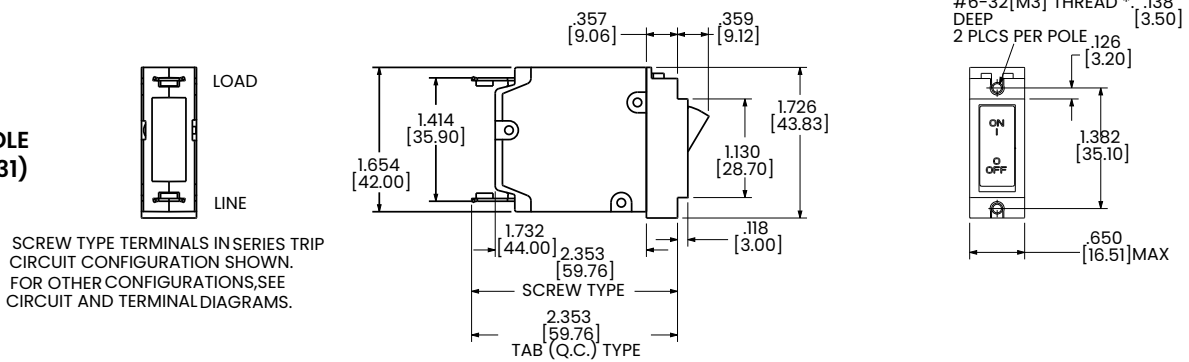

PUSH - TO - RESET ACTUATOR

1-POLE (H71)

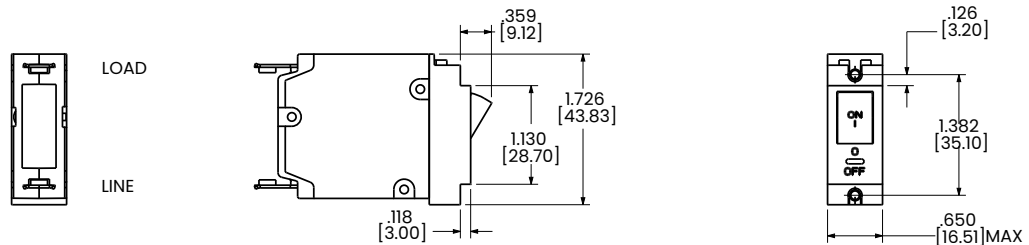

2-POLE (H72)

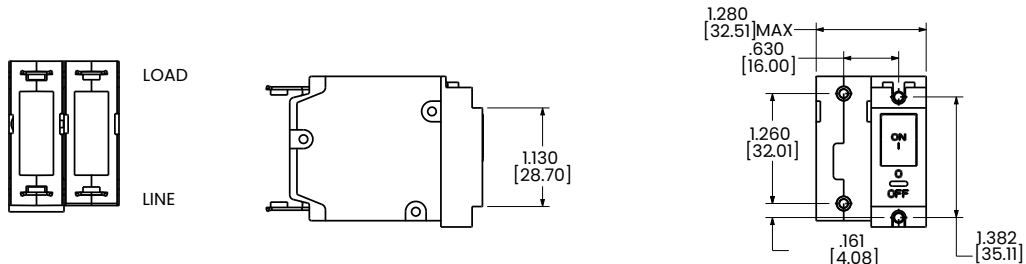

3-POLE (HJ3)

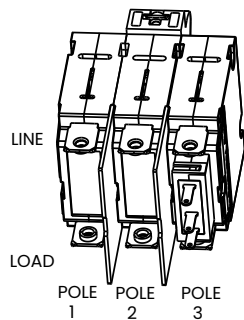
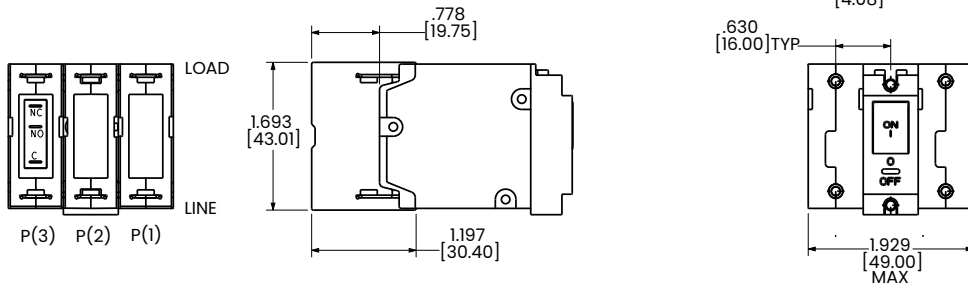

MULTI-POLE IDENTIFICATION SCHEME AS VIEWED FROM TERMINAL END OF BREAKER.

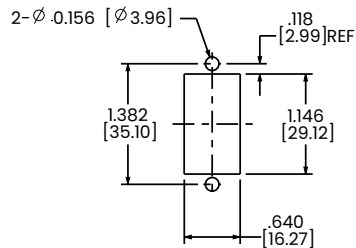

PANEL CUTOUT DETAIL
TOLERANCES ±.005 [±.12]
UNLESS OTHERWISE SPECIFIED

Notes:

1 Tolerance ±.020 [.51] unless otherwise specified.

PC Terminal Diagrams

Curved and Flat Rocker

inches [millimeters]

PRINTED CIRCUIT BOARD MOUNTING TERMINAL CODE R

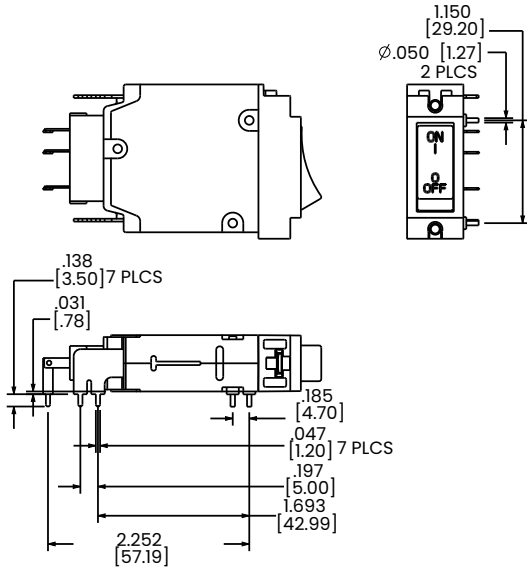

PRINTED CIRCUIT BOARD MOUNTING TERMINAL CODE L

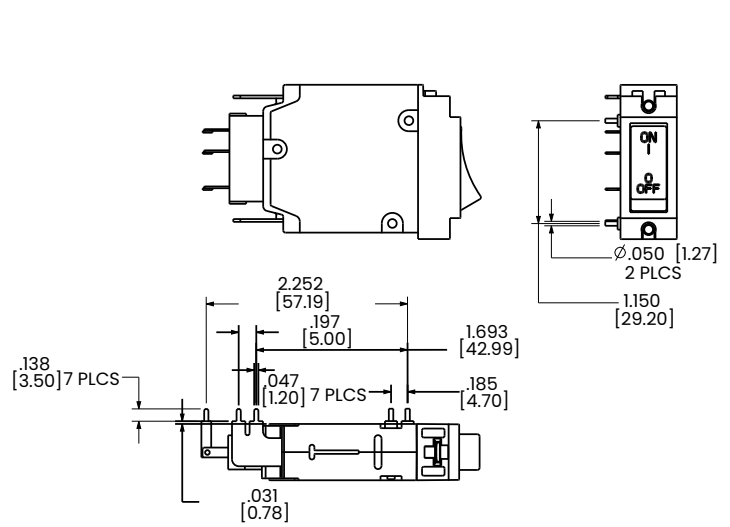

PRINTED CIRCUIT BOARD MOUNTING TERMINAL CODE S & T

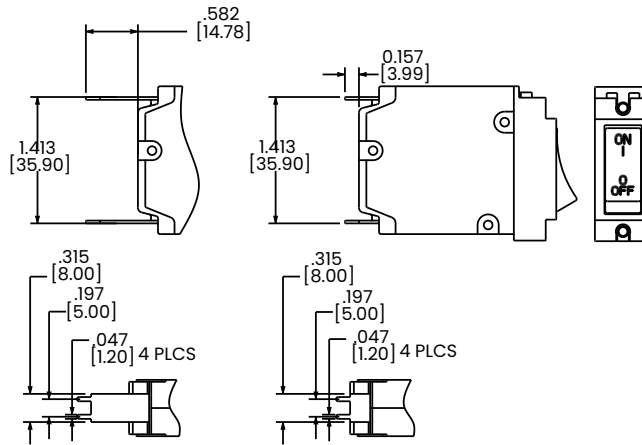

P.C. TERMINAL T

P.C. TERMINAL S

Notes:

1 Tolerance $\pm.020$ [.51] unless otherwise specified.

PC Terminal Diagrams

Curved and Flat Rocker

inches [millimeters]

P.C. FOOT PRINT FOR TERMINAL CODE R

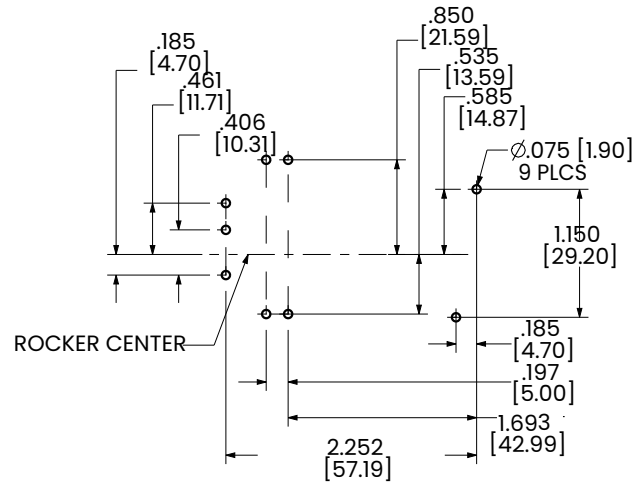

P.C. FOOT PRINT FOR TERMINAL CODE L

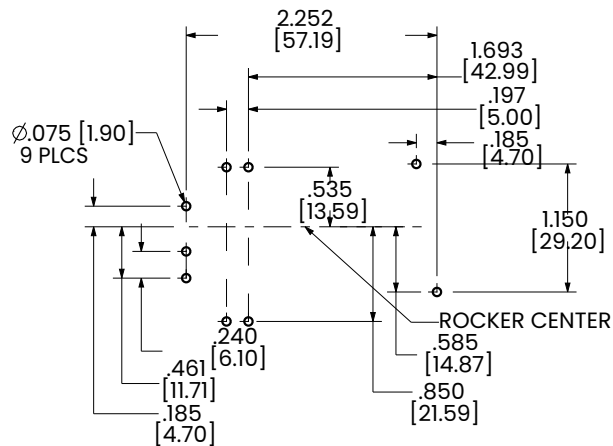

P.C. FOOT PRINT FOR TERMINAL CODES S & T

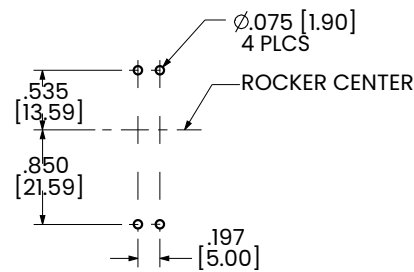

Notes:
1 Tolerance \pm .020 [.51] unless otherwise specified.

Circuit & Terminal Diagram

inches [millimeters]

HANDLE POSITION VS. AUX SWITCH MODE		
STANDARD C/B		
CIRCUIT BREAKER MODE	HANDLE POSITION	AUX. SWITCH MODE
OFF		
ON		
ELECTRICAL TRIP		

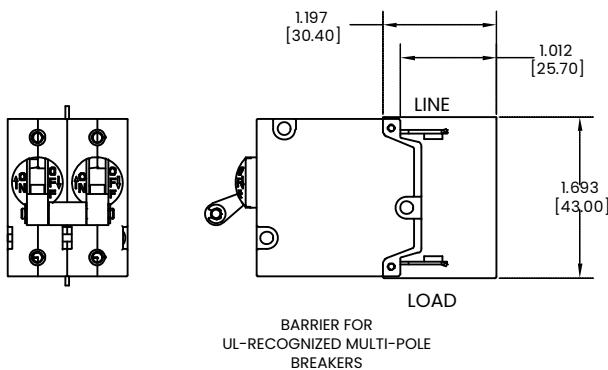
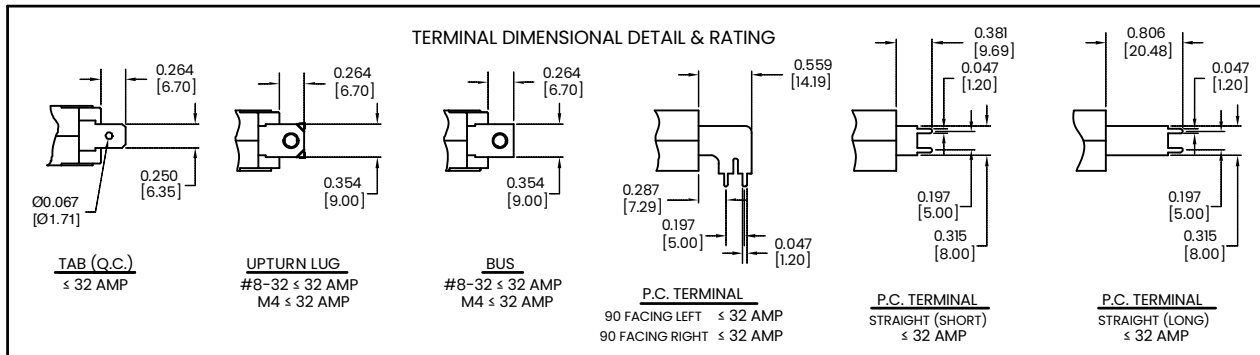
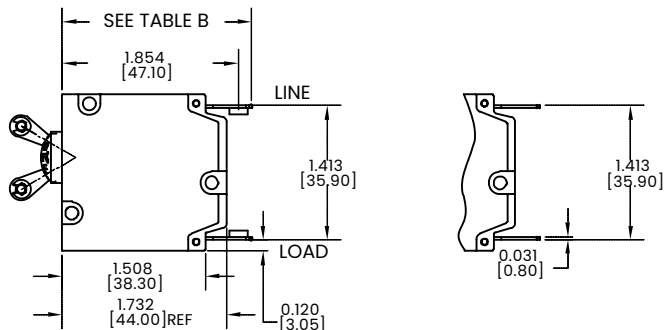

**TABLE A
TIGHTENING TORQUE SPECIFICATIONS**

THREAD SIZE	TORQUE
#6-32 & M3 MOUNTING HARDWARE	7-9 IN-LBS [0.8-1.0 NM]
#8-32 & M4 THREAD TERMINAL SCREW	12-15 IN-LBS [1.4-1.7 NM]

TABLE B

TERMINAL DESCRIPTION	DEPTH BEHIND PANEL	
MAIN	TAB (Q.C.)	1.996 [50.70]
	SCREW TYPE	1.996 [50.70]
AUX. SWITCH*	.110 TAB (Q.C.)	2.467 [62.67]
	SOLDER TYPE	2.252 [57.19]



* AVAILABLE ON SERIES TRIP AND SWITCH ONLY CIRCUITS. WHEN CALLED FOR ON MULTI-POLE UNITS, ONLY ONE AUX. SWITCH IS NORMALLY SUPPLIED, AS SHOWN IN MULTI-POLE IDENTIFICATION SCHEME.

1. ALL DIMENSIONS ARE IN INCHES [mm]
2. TOLERANCE ±.020 [.51] UNLESS OTHERWISE SPECIFIED.

Circuit & Terminal Diagram

inches [millimeters]

CIRCUIT BREAKER PROFILE	CIRCUIT SCHEMATIC		CIRCUIT SCHEMATIC			
	ANSI	CIRCUIT CODE	ANSI	CIRCUIT CODE		
2 TERMINALS 	SWITCH ONLY (NO COIL) 	A	0	SERIES TRIP 	B C	0
5 TERMINALS 	SWITCH ONLY (NO COIL) WITH AUXILIARY SWITCH 	A	1 2 3 4	SERIES TRIP WITH AUXILIARY 	B C	1 2 3 4
3 TERMINALS 	SHUNT TRIP 	D E	0			
4 TERMINALS 	RELAY TRIP 	F G	0			

AUXILIARY SWITCH TERMINAL DETAIL

